

Outdoor Telephone

WTS IP

Application

The WTS IP telephone set is a rugged, weatherproof unit for use outdoors or in tough ambient conditions. It can be wall or desk mounted. The WTS IP is best suited to be used in industrial areas, power plants, and switchyards.

Technical Data

Housing:	Polycarbonate
Housing Dimensions:	height x width x depth 293 x 191 x 128 mm
Weight:	approx. 2.3 kg
Protection Degree:	IP 65 according to IEC60529
Power Supply:	Power over LAN (IEEE 802.3af) 48V, 3.5W
Connection Plugs:	2x Ethernet: RJ-45, 10/100-BASE-TX auto negotiation
Ringing Volume:	approx. 95 dB(A) at 1 m distance
Display:	128 x 64 Pixel
Temperature Range:	-20°C...+60°C
Protocols:	SIP, H.323 H.323 version 4 incl. H.225, H.235, H.245 and RAS Gatekeeper routed Signalling, H.450 Session Initiation Protocol (SIP) RTP Real Time Protocol First level of Quality of Service
RTCP:	Support for External Gatekeeper
RAS Protocol:	H.245 Alphanumeric or Signal Type
DTMF:	H.245 Fast Connect En-block dialling Overlapped Sending
VoIP-Features:	Password Protected Administration Encoded Password Authorization acc. to H.235
Security:	Priority of IP-Packages acc. to TOS and DiffServ, VLAN Priority acc. to IEEE 802.1p / 802.1q
Quality of Service:	G.711 A-law / u-law (64 kbps), G.723.1 (5.3 kbps), G.729A (16kbps)
Voice Encoding:	G.168
Echo Compensation:	via HTML Web-Browser Password protected authentication
Access:	Log- and Trace-Files, State Display of Interfaces and Connections, Ping Connection Test sending of SNMP Traps over Internet Protocol
Troubleshooting:	Configuration recording/reading, Boot code and firmware update via HTML upload, Automatic update via Update-Server
Update:	PPPoE Protocol
DSL-Access:	Tunnelling with PPTP Encoding via MPPE
VPN:	For Transformation of official IP Addresses into private IP Addresses and vice versa
NAT:	For IP interfaces settings
DHCP:	For Ping tests
ICMP:	Automatic Dial tone Generation European and US Standard
Dial Tone Generation:	Call Transfer with/without consultation call
Call Transfer:	Call Diversion Unconditional, Busy, No Reply
Call Diversion:	Call Hold / Retrieve
Call Hold / Retrieve:	Call Waiting inclusive Signalling of second Call Information
Call Waiting:	Message Waiting Indication
Message Waiting:	Calling Name Identification: Name Display
Calling Name Identification:	3 Party Conference of internal and/or external Subscriber
3 Party Conference :	Display of Calling Number
CLIP:	Up to 6 Registrations
Multiple Registrations:	Local, Integration of an External Database
Telephone Book:	Exact Time and Date Information via Time Server
Time/Date:	

- Protection Class IP65
- Ambient Temp.-20°C to +60°C
- Wall or Desk mounting
- Call Buzzer volume 95dB(A), 1m
- Standard SIP and H.323
- PoE as per IEEE 802.3af
- 2x RJ45
- illuminated display



Telecommunications

For further information please contact:

BlueCom AG
Giessenstrasse 15
CH-8953 Dietikon
Tel.: +41 44 748 48 18
Fax: +41 44 748 48 19
E-mail: sales@bluecom.ch
Internet: www.bluecom.ch

Dimensions:

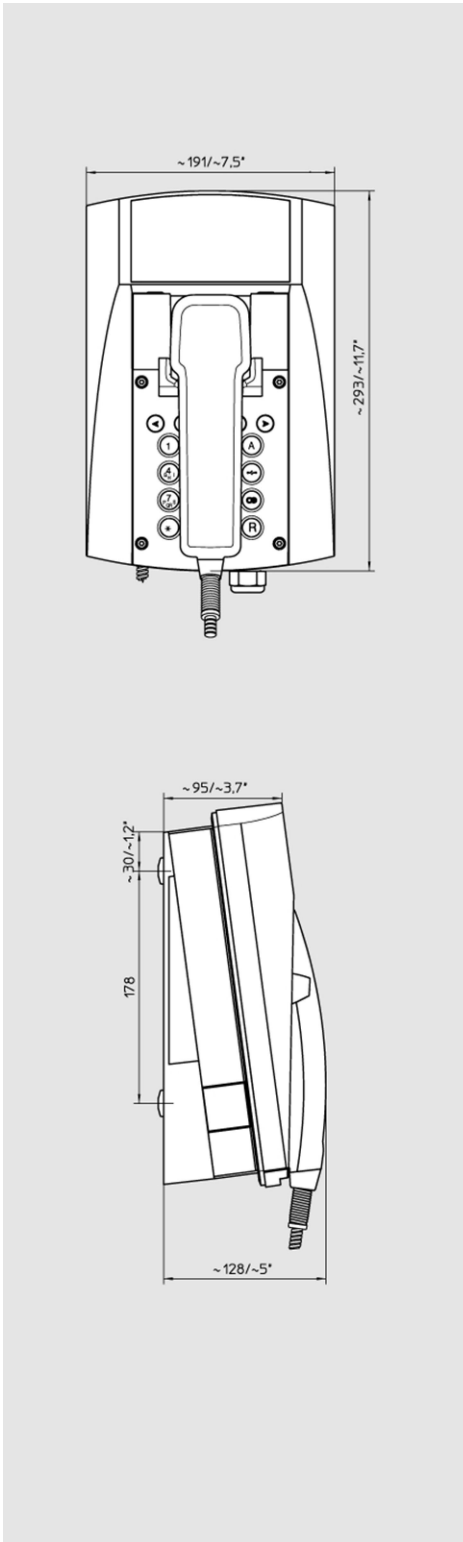

Ordering Information

Description	Order No.
VoIP Outdoor Telephone WGS-IP with spiral cord	BCTS1063
VoIP Outdoor Telephone WGS-IP with steel armoured cord	BCTS1065

WTS-IP-EICTS10x.DS.E1 01/11

Printed in Switzerland

Due to continuous product improvements this specification is subject to change without notice



For further information please contact:

BlueCom AG
 Giessenstrasse 15
 CH-8953 Dietikon
 Tel.: +41 44 748 48 18
 Fax: +41 44 748 48 19
 E-mail: sales@bluecom.ch
 Internet: www.bluecom.ch