

SIEMENS

RUGGEDCOM RX1501

Installation Guide

Preface

Introduction

1

Installing the Device

2

Communication Ports

3

Technical Specifications

4

Dimension Drawings

5

Certification

6

Copyright © 2014 Siemens Canada Ltd.

All rights reserved. Dissemination or reproduction of this document, or evaluation and communication of its contents, is not authorized except where expressly permitted. Violations are liable for damages. All rights reserved, particularly for the purposes of patent application or trademark registration.

This document contains proprietary information, which is protected by copyright. All rights are reserved. No part of this document may be photocopied, reproduced or translated to another language without the prior written consent of Siemens Canada Ltd..

Disclaimer Of Liability

Siemens has verified the contents of this manual against the hardware and/or software described. However, deviations between the product and the documentation may exist.

Siemens shall not be liable for any errors or omissions contained herein or for consequential damages in connection with the furnishing, performance, or use of this material.

The information given in this document is reviewed regularly and any necessary corrections will be included in subsequent editions. We appreciate any suggested improvements. We reserve the right to make technical improvements without notice.

Registered Trademarks

ROX™, Rugged Operating System On Linux™, CrossBow™ and ELAN™ are trademarks of Siemens Canada Ltd.. ROS® is a registered trademark of Siemens Canada Ltd..

Other designations in this manual might be trademarks whose use by third parties for their own purposes would infringe the rights of the owner.

Security Information

Siemens provides products and solutions with industrial security functions that support the secure operation of plants, machines, equipment and/or networks. They are important components in a holistic industrial security concept. With this in mind, Siemens' products and solutions undergo continuous development. Siemens recommends strongly that you regularly check for product updates.

For the secure operation of Siemens products and solutions, it is necessary to take suitable preventive action (e.g. cell protection concept) and integrate each component into a holistic, state-of-the-art industrial security concept. Third-party products that may be in use should also be considered. For more information about industrial security, visit <http://www.siemens.com/industrialsecurity>.

To stay informed about product updates as they occur, sign up for a product-specific newsletter. For more information, visit <http://support.automation.siemens.com>.

Warranty

Siemens warrants this product for a period of five (5) years from the date of purchase, conditional upon the return to factory for maintenance during the warranty term. This product contains no user-serviceable parts. Attempted service by unauthorized personnel shall render all warranties null and void. The warranties set forth in this article are exclusive and are in lieu of all other warranties, performance guarantees and conditions whether written or oral, statutory, express or implied (including all warranties and conditions of merchantability and fitness for a particular purpose, and all warranties and conditions arising from course of dealing or usage or trade). Correction of nonconformities in the manner and for the period of time provided above shall constitute the Seller's sole liability and the Customer's exclusive remedy for defective or nonconforming goods or services whether claims of the Customer are based in contract (including fundamental breach), in tort (including negligence and strict liability) or otherwise.

For warranty details, visit www.siemens.com/ruggedcom or contact a Siemens customer service representative.

Contacting Siemens

Address

Siemens Canada Ltd.
Industry Sector
300 Applewood Crescent
Concord, Ontario
Canada, L4K 5C7

Telephone

Toll-free: 1 888 264 0006
Tel: +1 905 856 5288
Fax: +1 905 856 1995

E-mail

ruggedcom.info.i-ia@siemens.com

Web

www.siemens.com/ruggedcom

Table of Contents

Preface	v
Alerts	v
Related Documents	v
Accessing Documentation	v
Training	vi
Customer Support	vi
 Chapter 1	
Introduction	1
1.1 Feature Highlights	1
1.2 Ports, Controls and Indicator LEDs	3
 Chapter 2	
Installing the Device	5
2.1 Mounting the Device	5
2.1.1 Mounting the Device to a Rack	6
2.1.2 Mounting the Device on a DIN Rail	7
2.1.3 Mounting the Device to a Panel	8
2.2 Connecting Power	8
2.2.1 Installing/Removing Power Supplies	9
2.2.1.1 Installing a Power Supply	9
2.2.1.2 Removing a Power Supply	10
2.2.2 Connecting High AC/DC Power	11
2.2.3 Connecting Low DC Power	12
2.3 Connecting the Failsafe Alarm Relay	13
2.4 Grounding the Device	13
2.5 Connecting to the Device	14
2.6 Cabling Recommendations	15
2.6.1 Protection On Twisted-Pair Data Ports	15
2.6.2 Gigabit Ethernet 1000Base-TX Cabling Recommendations	15
 Chapter 3	
Communication Ports	17
3.1 Copper Ethernet Ports	18
3.2 Fiber Optic Ethernet Ports	20

3.3	SFP Optic Ethernet Ports	21
3.3.1	Installing an SFP Optical Port	21
3.3.2	Removing an SFP Optical Port	22
3.4	WAN Modules	23
3.5	Serial Ports	24
3.6	Cellular Modem Modules	25
3.6.1	Cellular Modem Installation Requirements	27
3.6.2	Diversity Requirements	28
3.6.3	Supported Frequency Bands	28
3.6.4	Installing SIM Cards for GSM, EDGE and HSPA+ Cellular Modems	29
3.7	DDS (Digital Data Services) Modules	30
3.8	RUGGEDCOM APE Module	31
3.9	Installing/Removing Modules	32
3.9.1	Installing a Module	32
3.9.2	Removing a Module	33
3.10	Connecting Multiple RS485 Devices	34
Chapter 4		
	Technical Specifications	37
4.1	Power Supply Specifications	37
4.2	Failsafe Relay Specifications	38
4.3	Copper Serial Port Specifications	38
4.4	Copper Ethernet Port Specifications	38
4.5	Fiber Optic Ethernet Port Specifications	39
4.5.1	Fast Ethernet (100 Mbps) Optical Specifications	39
4.5.2	Gigabit Ethernet (1 Gbps) Optical Specifications	40
4.6	Cellular Modem Specifications	41
4.7	Operating Environment	42
4.8	RUGGEDCOM APE Specifications	42
4.9	Mechanical Specifications	43
Chapter 5		
	Dimension Drawings	45
Chapter 6		
	Certification	47
6.1	Agency Approvals	47
6.2	FCC Compliance	48
6.3	Industry Canada Compliance	48
6.4	EMI and Environmental Type Tests	48

Preface

This guide describes the RUGGEDCOM RX1501. It describes the major features of the device, installation, commissioning and important technical specifications.

It is intended for use by network technical support personnel who are responsible for the installation, commissioning and maintenance of the device. It is also recommended for use by network and system planners, system programmers, and line technicians.

Alerts

The following types of alerts are used when necessary to highlight important information.



DANGER!

DANGER alerts describe imminently hazardous situations that, if not avoided, will result in death or serious injury.



WARNING!

WARNING alerts describe hazardous situations that, if not avoided, may result in serious injury and/or equipment damage.



CAUTION!

CAUTION alerts describe hazardous situations that, if not avoided, may result in equipment damage.



IMPORTANT!

IMPORTANT alerts provide important information that should be known before performing a procedure or step, or using a feature.



NOTE

NOTE alerts provide additional information, such as facts, tips and details.

Related Documents

Other documents that may be of interest include:

- *ROX II User Guide for the RX1501*

Accessing Documentation

The latest Hardware Installation Guides and Software User Guides for most RUGGEDCOM products are available online at www.siemens.com/ruggedcom.

For any questions about the documentation or for assistance finding a specific document, contact a Siemens sales representative.

Training

Siemens offers a wide range of educational services ranging from in-house training of standard courses on networking, Ethernet switches and routers, to on-site customized courses tailored to the customer's needs, experience and application.

Siemens' Educational Services team thrives on providing our customers with the essential practical skills to make sure users have the right knowledge and expertise to understand the various technologies associated with critical communications network infrastructure technologies.

Siemens' unique mix of IT/Telecommunications expertise combined with domain knowledge in the utility, transportation and industrial markets, allows Siemens to provide training specific to the customer's application.

For more information about training services and course availability, visit www.siemens.com/ruggedcom or contact a Siemens sales representative.

Customer Support

Customer support is available 24 hours, 7 days a week for all Siemens customers. For technical support or general information, contact Siemens Customer Support through any of the following methods:

- **Online**

Visit <http://www.siemens.com/automation/support-request> to submit a Support Request (SR) or check on the status of an existing SR.

- **Telephone**

Call a local hotline center to submit a Support Request (SR). To locate a local hotline center, visit .

- **Mobile App**

Install the Industry Online Support app by Siemens AG on any Android, Apple iOS or Windows mobile device and be able to:

- Access Siemens' extensive library of support documentation, including FAQs, manuals, and much more
- Submit SRs or check on the status of an existing SR
- Find and contact a local contact person
- Ask questions or share knowledge with fellow Siemens customers and the support community
- And much more...

1 Introduction

The RUGGEDCOM RX1501 is a cost-efficient, rugged Layer 3 switch and router. The RX1501's modular and field replaceable platform can be equipped with WAN, serial, and Ethernet options, making it ideally suited for electric power utilities, the industrial plant floor, and traffic control systems.

The RX1501 is designed to provide a high level of immunity to electromagnetic interference (EMI) and heavy electrical surges typical of the harsh environments found in many industrial applications. An operating temperature range of -40 to 85 °C (-40 to 185 °F) allows the RX1501 to be placed in almost any location.

The following sections provide more information about the RX1501:

- [Section 1.1, "Feature Highlights"](#)
- [Section 1.2, "Ports, Controls and Indicator LEDs"](#)

Section 1.1

Feature Highlights

Cyber Security Features

- Multi-level passwords
- SSH/SSL encryption
- Enable/disable ports, MAC-based port security
- Port-based network access control (802.1x)
- VLAN (802.1Q) to segregate and secure network traffic
- RADIUS centralized password management
- SNMPv3 encrypted authentication and access security

Reliability in Harsh Environments

- Immunity to EMI and high voltage electrical transients:
 - Meets IEEE 1613 (electric utility substations)
 - Exceeds IEC 61850-3 (electric utility substations)
 - Exceeds IEC 61800-3 (variable speed drive systems)
 - Exceeds IEC 61000-6-2 (generic industrial environment)
 - Exceeds NEMA TS-2 (traffic control equipment)
- -40 to 85 °C (-40 to 185 °F) operating temperature (no fans)
- Failsafe output relay for critical failure or error alarming

Physical Ports

- Field replaceable line modules
- Up to 36 ports 100FX
- Up to 36 ports 10/100TX

- Up to 8 ports Gigabit Ethernet

WAN Port Options

- T1/E1 (channelized)
- E1 75 Ω via BNC
- Cellular (HSPA/EVDO)
- DDS

Serial Ports

- Fully compliant EIA/TIA RS485, RS422 and RS232 serial ports (software selectable) with RJ45 connectors, DNP and MODBUS
- Raw socket mode support allows encapsulation of any serial protocol

Protocols

- **WAN**
 - Frame Relay RFC 1490 or RFC 1294
 - PPP RFC 1661, 1332, 1321, 1334, PAP, CHAP Authentication
 - Multilink PPP RFC 1990
 - GOOSE messaging support
- **IP**
 - OSPF, BGP, RIPv1, RIPv2
 - VRRP
 - Traffic control, NTP Server, IP Multicast Routing
 - DHCP Agent (Option 82 Capable)
 - PIM-SM

Advanced Services

- MPLS Static Label Support

Frame Relay Support

- ISO and ITU compliant, network certified.
- ANSI T1.617 Annex D, Q.933 or LMI Local Signalling

Management Tools

- Web-based, SSH and CLI management interfaces
- SNMP v1, v2 and v3
- NETCONF
- Remote syslog
- Rich set of diagnostics with logging and alarms
- Loopback diagnostic tests
- Raw and interpreted real-time line traces

Universal Power Supply Options

- Single, removable power supply module
- Fully integrated power supply (no external adapter)

- Input voltage ranges: 13-36 VDC and 37-72 VDC or 85-264 VAC and 88-300 VDC for worldwide operability
- CSA/UL 60950-1 safety approved to 85 °C (185 °F)

Section 1.2

Ports, Controls and Indicator LEDs

The RX1501 features various ports, controls and indicator LEDs on the front panel for configuring and troubleshooting the device.

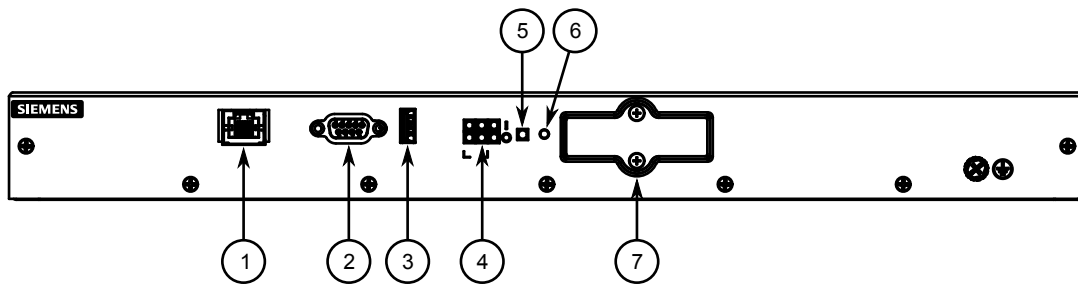

Figure 1: Front Panel

1. Management Port 2. RS232 Serial Console Port (DB9) 3. Utility USB Port 4. Port Status Indicator LEDs 5. Alarm Indicator LED
6. Lamp Test/Alarm Cut-Off (LT/ACO) Button 7. Compact Flash Card Port

Management Port	This 10/100Base-T Ethernet port is used for system management that is out-of-band from the switch fabric.
RS232 Serial Console Port	This port is for interfacing directly with the device and accessing initial management functions.
Utility USB Port	The USB port can be used to upgrade the ROX II software or install files, such as configuration files and feature key files.
Lamp Test/Alarm Cut-Off (LT/ACO) Button	This button performs two functions: <ul style="list-style-type: none"> • Press and hold this button to test all indicator LEDs • Press and release this button to acknowledge an active alarm
Power Module Indicator LEDs	These LEDs indicate the status of the power modules. <ul style="list-style-type: none"> • I = The power supply is receiving power • O = The power supply is supplying power
Port Status Indicator LEDs	These LEDs indicate when ports are active. <ul style="list-style-type: none"> • Green = OK • Orange = Warning alert • Red = Configuration error
Alarm Indicator LED	The alarm indicator LED indicates when an alarm condition exists. <ul style="list-style-type: none"> • Green = Alarms cleared/acknowledged • Red = Alarm
Compact Flash Card Port	This port houses the 1 GB compact flash card that contains active and backup installations of ROX II, along with the configuration database and other system data.



CAUTION!

Configuration hazard – risk of data corruption/loss. Do not open the compact flash card port, unless specifically instructed to by a Siemens Customer Support representative. The warranty will be void otherwise. Removing the compact flash card improperly can corrupt configuration data.

2 Installing the Device

The following sections describe how to install the device, including mounting the device, connecting power, and connecting the device to the network.



WARNING!

Radiation hazard – risk of serious personal injury. This product contains a laser system and is classified as a CLASS 1 LASER PRODUCT. Use of controls or adjustments or performance of procedures other than those specified herein may result in hazardous radiation exposure.



DANGER!

Electrocution hazard – risk of serious personal injury and/or damage to equipment. Before performing any maintenance tasks, make sure all power to the device has been disconnected and wait approximately two minutes for any remaining energy to dissipate.



IMPORTANT!

This product contains no user-serviceable parts. Attempted service by unauthorized personnel shall render all warranties null and void.

Changes or modifications not expressly approved by Siemens Canada Ltd. could invalidate specifications, test results, and agency approvals, and void the user's authority to operate the equipment.



IMPORTANT!

This product should be installed in a restricted access location where access can only be gained by authorized personnel who have been informed of the restrictions and any precautions that must be taken. Access must only be possible through the use of a tool, lock and key, or other means of security, and controlled by the authority responsible for the location.

- [Section 2.1, “Mounting the Device”](#)
- [Section 2.2, “Connecting Power”](#)
- [Section 2.3, “Connecting the Failsafe Alarm Relay”](#)
- [Section 2.4, “Grounding the Device”](#)
- [Section 2.5, “Connecting to the Device”](#)
- [Section 2.6, “Cabling Recommendations”](#)

Section 2.1

Mounting the Device

The RX1501 is designed for maximum mounting and display flexibility. It can be equipped with connectors that allow it to be installed in a 48 cm (19 in) rack, 35 mm (1.4 in) DIN rail or directly on a panel.



NOTE

For detailed dimensions of the device with either rack, DIN rail or panel hardware installed, refer to Chapter 5, Dimension Drawings.

The following sections describe the various methods of mounting the device:

- [Section 2.1.1, “Mounting the Device to a Rack”](#)
- [Section 2.1.2, “Mounting the Device on a DIN Rail”](#)
- [Section 2.1.3, “Mounting the Device to a Panel”](#)

Section 2.1.1

Mounting the Device to a Rack

For rack mount installations, the RX1501 can be equipped with rack mount adapters pre-installed at the front or rear of the chassis. Additional adapters are provided for added stability.



CAUTION!

Vibration hazard – risk of damage to the device. Always use four rack mount adapters (two at the front of the device and two at the rear) when installing the device in high-vibration or seismically active locations.



CAUTION!

Electrical/mechanical hazard – risk of damage to the device. Before installing the device in a rack, make sure of the following:

- *When installing the device in a closed or multi-device rack, be aware that the operating ambient temperature of the rack may be higher than the ambient temperature of the room. Make sure the rack is installed in a suitable environment that can withstand the maximum ambient temperature generated by the rack.*
- *Make sure each device in the rack is separated by at least one rack-unit of space, or 44 mm (1.75 in), to promote convectional airflow. Forced airflow is not required. However, any increase in airflow will result in a reduction of ambient temperature and improve the long-term reliability of all equipment mounted in the rack space.*
- *Do not exceed the maximum number of devices or weight restrictions specified by the rack manufacturer.*
- *Do not overload the supply circuit. Refer to the over-current protection and power supply ratings specified by the rack manufacturer.*
- *Make sure the rack and all devices have a proper ground-to-Earth connection. Pay particular attention to power supply connections other than direct connections to the branch circuit (e.g. power strips).*

To secure the device to a standard 48 cm (19 in) rack, do the following:

1. Make sure the rack mount adapters are installed on the correct side of the chassis.
 - To make the modules and ports accessible, install the rack mount adapters at the rear of the chassis
 - To make the management ports and LEDs accessible, install the rack mount adapters at the front of the chassis



NOTE

The chassis features multiple mounting holes, allowing the rack mount adapters to be installed up to 25 mm (1 in) from the face of the device.

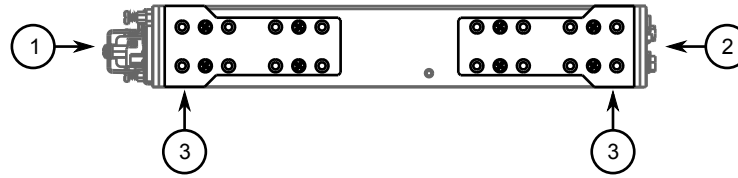

Figure 2: Rack Mount Adapters

1. Rear 2. Front 3. Rack Mount Adapter

2. If required, install adapters on the opposite side of the device to protect from vibrations.
3. Insert the device into the rack.
4. Secure the adapters to the rack using the supplied hardware.

Section 2.1.2

Mounting the Device on a DIN Rail

For DIN rail installations, the RX1501 can be equipped with panel/DIN rail adapters pre-installed on each side of the chassis. The adapters allow the device to be slid onto a standard 35 mm (1.4 in) DIN rail.

To mount the device to a DIN rail, do the following:

1. Align the adapters with the DIN rails and slide the device into place.

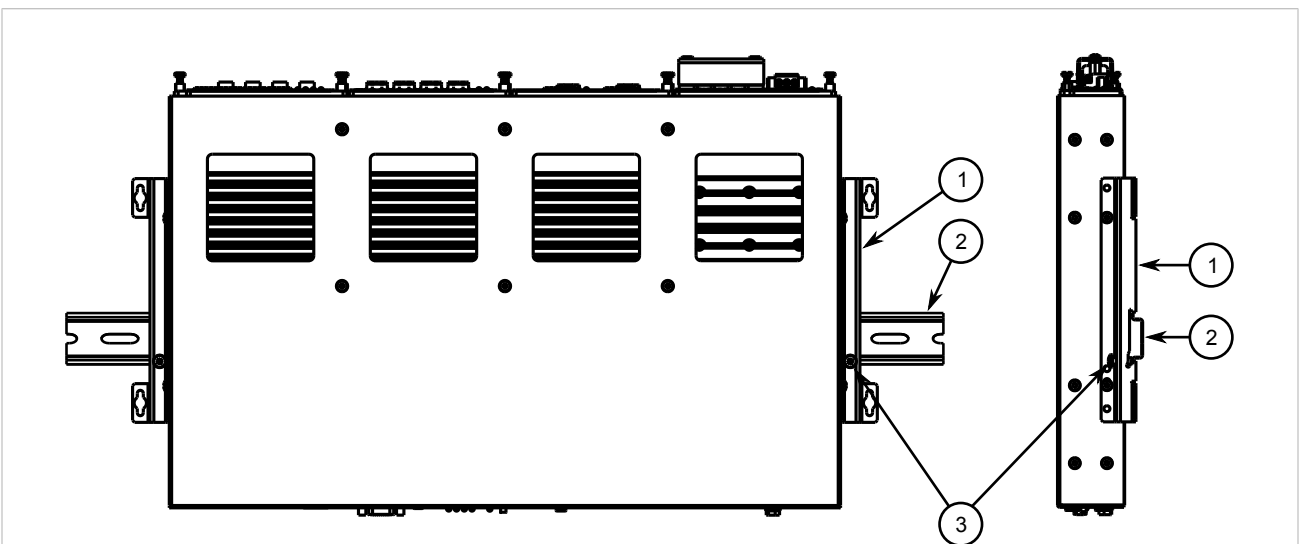

Figure 3: DIN Rail Mounting

1. Panel/DIN Rail Adapter 2. DIN Rail 3. Screw

2. Install one of the supplied screws on either side of the device to secure the adapters to the DIN rails.

Section 2.1.3

Mounting the Device to a Panel

For panel installations, the RX1501 can be equipped with panel/DIN rail adapters pre-installed on each side of the chassis. The adapters allow the device to be attached to a panel using screws.

To mount the device to a panel, do the following:

1. Place the device against the panel and align the adapters with the mounting holes.

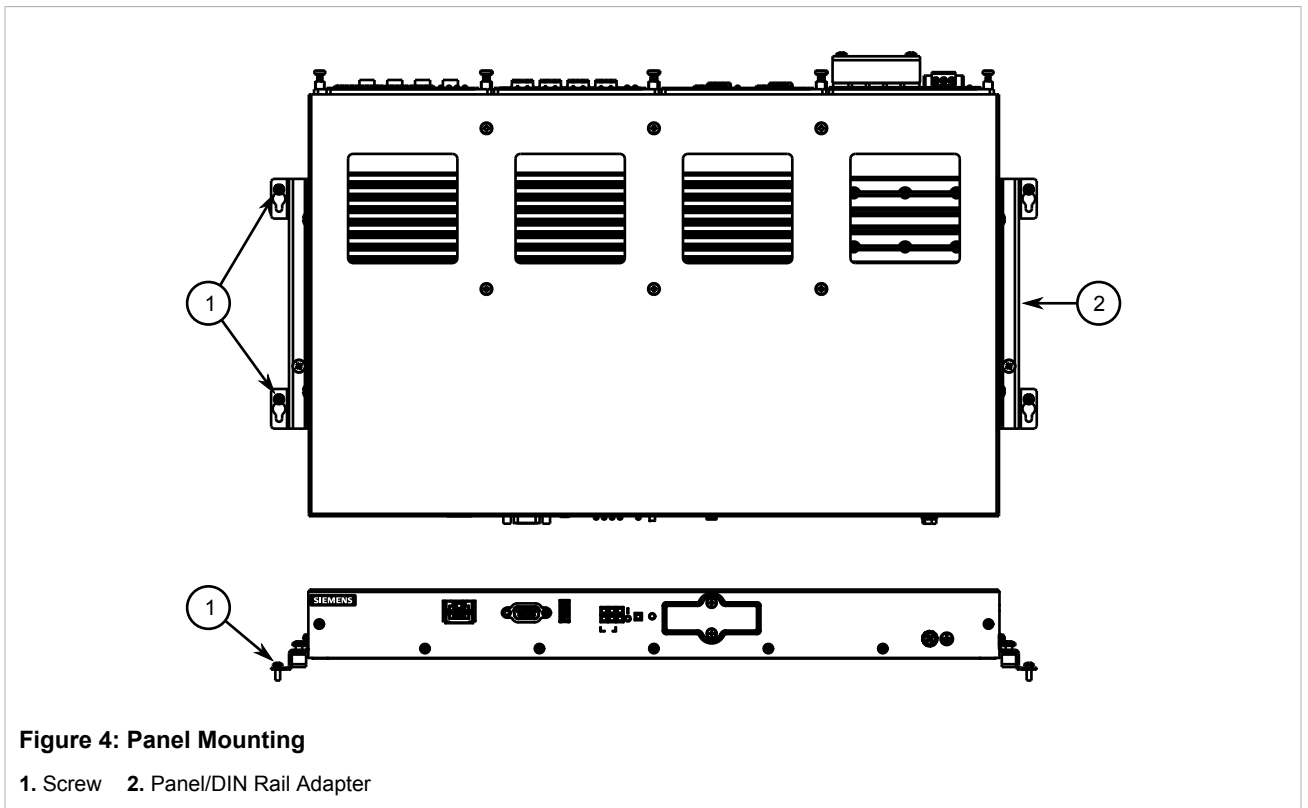

2. Install the supplied screws to secure the adapters to the panel.

Section 2.2

Connecting Power

The RX1501 supports a single high AC, high DC or low DC power supply.

The RX1501 can be equipped with either a screw-type or pluggable terminal block. The screw-type terminal block is installed using Phillips screws and compression plates, allowing either bare wire connections or crimped terminal lugs. Use #6 size ring lugs for secure, reliable connections under severe shock or vibration.



DANGER!

Electrocution hazard – risk of serious personal injury or death. Make sure the power source is off before servicing the power supply terminal.



IMPORTANT!

- Use only #16 gage copper wiring when connecting terminal blocks.
- The maximum wire length between the terminal block and power source must not exceed 6 m (20 ft) for 24 V power supplies or 18 m (60 ft) for 48 V power supplies.
- For 125/230 VAC rated equipment, an appropriately rated AC circuit breaker must be installed.
- For 125/250 VDC rated equipment, an appropriately rated DC circuit breaker must be installed.
- It is recommended to provide a separate 20 A circuit breaker for each power supply module.
- Equipment must be installed according to applicable local wiring codes and standards.

The following sections describe how to connect power to the device:

- [Section 2.2.1, “Installing/Removing Power Supplies”](#)
- [Section 2.2.2, “Connecting High AC/DC Power”](#)
- [Section 2.2.3, “Connecting Low DC Power”](#)

Section 2.2.1

Installing/Removing Power Supplies

The RX1501 supports a single AC or DC power supply.

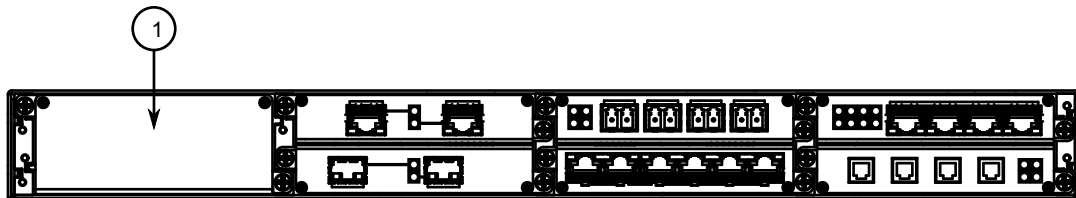

Figure 5: Power Module

1. Power Module

The following sections describe how to install, remove and connect the power supply:

- [Section 2.2.1.1, “Installing a Power Supply”](#)
- [Section 2.2.1.2, “Removing a Power Supply”](#)

Section 2.2.1.1

Installing a Power Supply

To install a power supply, do the following:

1. Remove the blank power module assembly or, if equipped, the currently installed power supply. For information about removing a power supply, refer to [Section 2.2.1.2, "Removing a Power Supply"](#).
2. Insert the power supply into the empty slot. When power is supplied to the device, the top and bottom LEDs on the power supply should be green, indicating that power is being received and supplied to the device.

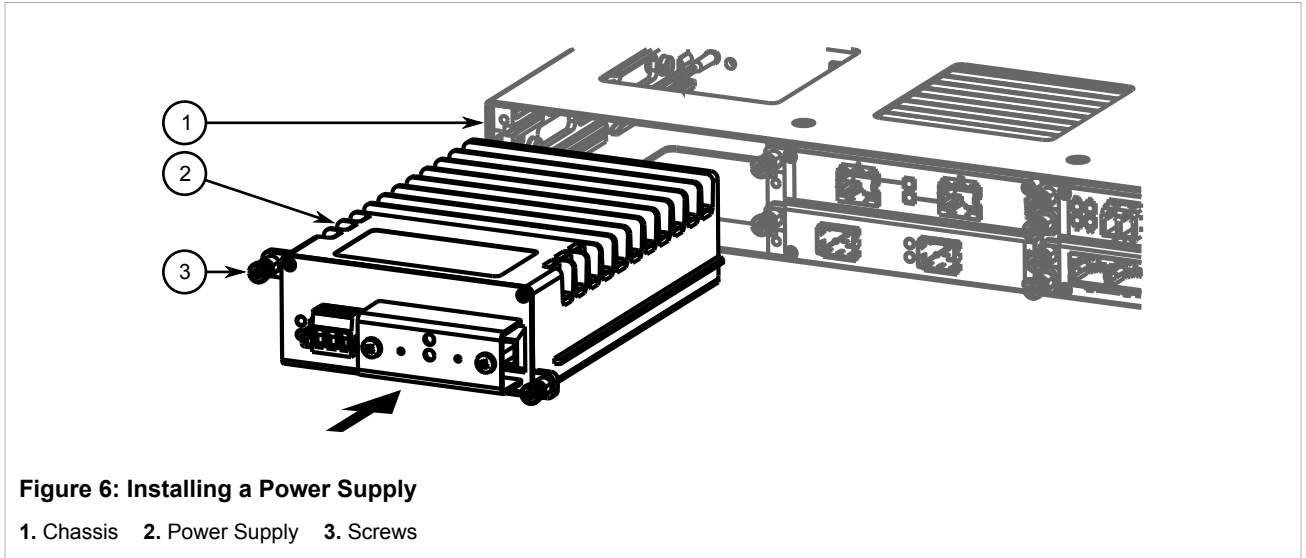

3. Hand-tighten the screws to secure the power supply.

Section 2.2.1.2

Removing a Power Supply

To remove a power supply, do the following:

1. Remove the screws that secure the power supply.
2. Pull the power supply from the chassis.

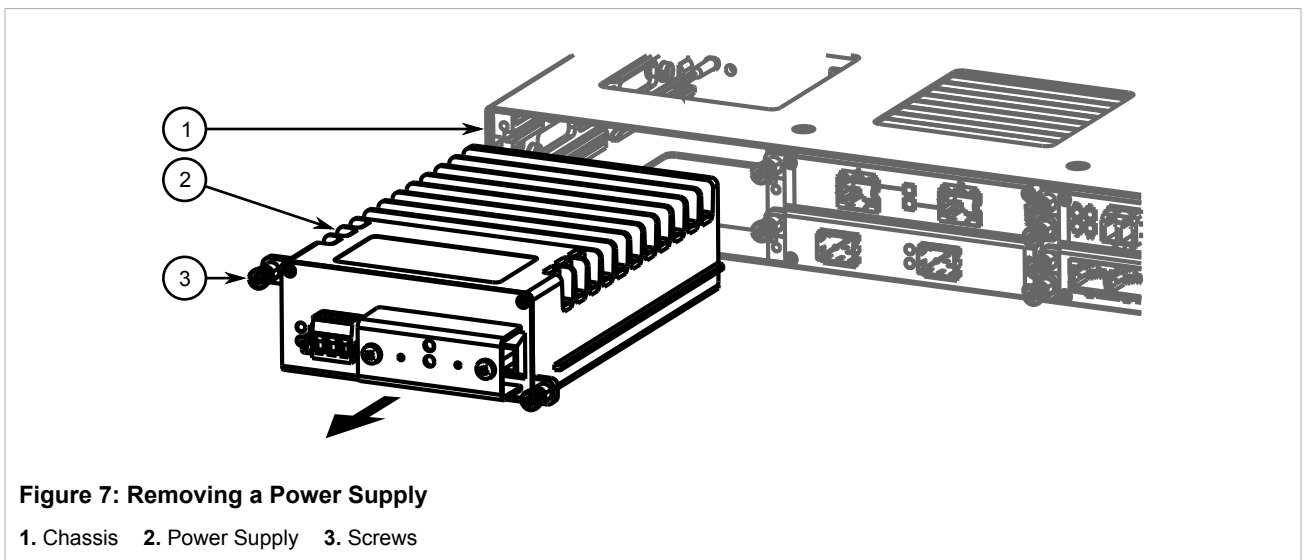

3. Install the blank power module assembly into the empty slot to prevent the ingress of dust and dirt.

Section 2.2.2

Connecting High AC/DC Power

To connect a high AC/DC power supply to the device, do the following:



DANGER!

Electrocution hazard – risk of death, serious personal injury and/or damage to the device. Make sure the supplied cover is always installed over high voltage screw-type terminal blocks.



CAUTION!

Electrical hazard – risk of damage to equipment. Do not connect AC power cables to a 12, 24 or 48 VDC power supply terminal block. Damage to the power supply may occur.



NOTE

The screw-type terminal block is installed using Phillips screws and compression plates, allowing either bare wire connections or crimped terminal lugs. Use #6 size ring lugs for secure, reliable connections.

1. Connect the positive wire from the power source to the positive/live (+/L) terminal on the terminal block.

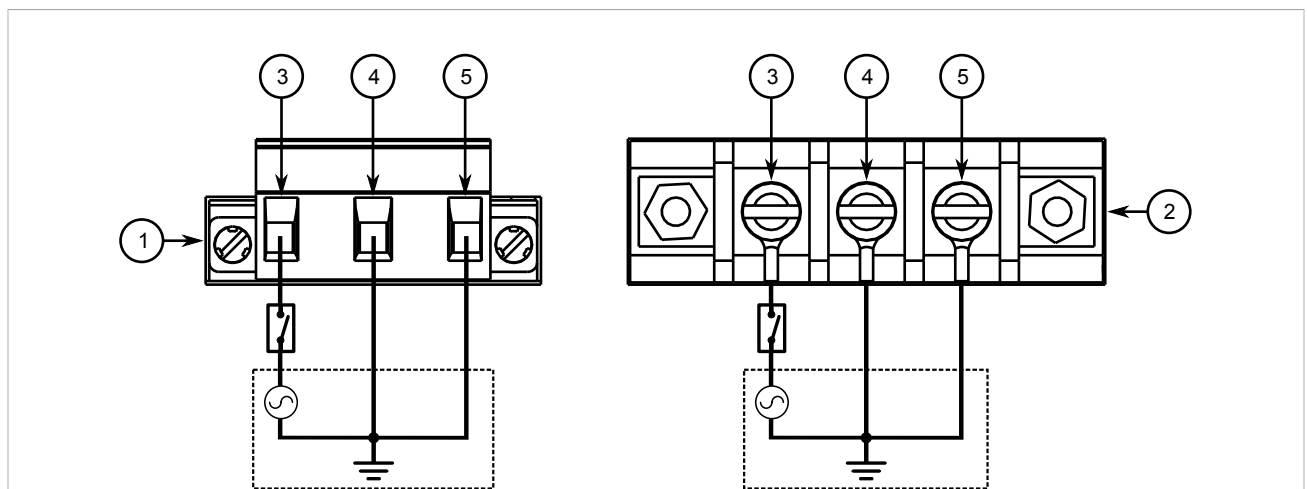

Figure 8: AC Terminal Block Wiring

1. Pluggable Terminal Block for HIP Power Supplies 2. Screw-Type Terminal Block for HI Power Supplies 3. Positive/Live (+/L) Terminal 4. Ground Terminal 5. Negative/Neutral (-/N) Terminal

2. Connect the negative wire from the power source to the neutral/negative (-/N) terminal on the terminal block.
3. Using a braided wire or other appropriate grounding wire, connect the ground terminal to the chassis ground connection. The ground terminal is used as the ground conductor for surge and transient suppression circuitry internal to the unit.
4. Connect the ground terminal on the power source to the ground terminal on the device. For more information, refer to [Section 2.4, "Grounding the Device"](#).

Section 2.2.3

Connecting Low DC Power

To connect a low DC power supply to the device, do the following:



CAUTION!

Electrical hazard – risk of damage to equipment. Do not connect AC power cables to a 12, 24 or 48 VDC power supply terminal block. Damage to the power supply may occur.



IMPORTANT!

When connecting the device to a DC power source, make sure the source provides only positive voltage.



NOTE

The screw-type terminal block is installed using Phillips screws and compression plates, allowing either bare wire connections or crimped terminal lugs. Use #6 size ring lugs for secure, reliable connections.

1. Connect the positive wire from the power source to the positive (+) terminal on the terminal block.

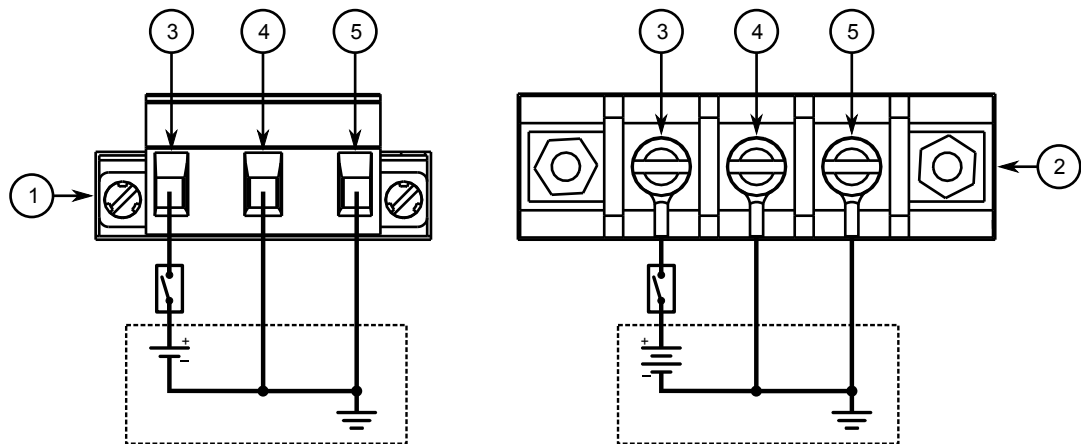

Figure 9: DC Terminal Block Wiring

1. Pluggable Terminal Block for HI, 24P and 48P Power Supplies 2. Screw-Type Terminal Block for HIP, 24 and 48 Power Supplies
3. Positive (+) Terminal 4. Negative (-) Terminal 5. Ground Terminal

2. Connect the negative wire from the power source to the negative (-) terminal on the terminal block.
3. Using a braided wire or other appropriate grounding wire, connect the ground terminal to the chassis ground connection. The surge ground terminal is used as the ground conductor for all surge and transient suppression circuitry internal to the unit.
4. Connect the ground terminal on the power source to the chassis ground terminal on the device. For more information, refer to [Section 2.4, "Grounding the Device"](#).

Section 2.3

Connecting the Failsafe Alarm Relay

The failsafe relay can be configured to latch based on alarm conditions. The NO (Normally Open) contact is closed when the unit is powered and there are no active alarms. If the device is not powered or if an active alarm is configured, the relay opens the NO contact and closes the NC (Normally Closed) contact.



NOTE

Control of the failsafe relay output is configurable through ROX II. One common application for this relay is to signal an alarm if a power failure occurs. For more information, refer to the ROX II User Guide for the RX1501.

The following shows the proper relay connections.

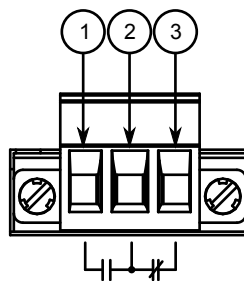

Figure 10: Failsafe Alarm Relay Wiring

- 1. Normally Open
- 2. Common
- 3. Normally Closed

Section 2.4

Grounding the Device

The RX1501 chassis ground terminal uses a #10-32 screw. It is recommended to terminate the ground connection with a #10 ring lug and torque it to 3.4 N·m (30 lbf·in).

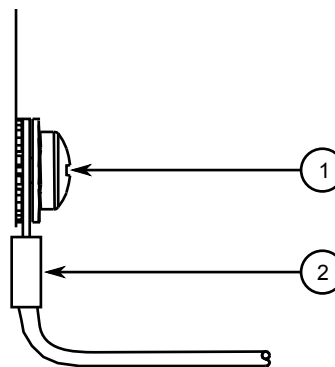

Figure 11: Chassis Ground Connection

- 1. #10-32 Screw
- 2. #10 Ring Lug

Section 2.5

Connecting to the Device

The following describes the various methods for accessing the ROX II console and Web interfaces on the device. For more detailed instructions, refer to the *ROX II User Guide* for the RX1501.

Serial Console and Management Ports

Connect a PC or terminal directly to the serial console or management ports to access the boot-time control and ROX II interfaces. The serial console port provides access to ROX II's console interface, while the management port provides access to ROX II's console and Web interfaces.



IMPORTANT!

The serial console and management (MGMT) ports are intended to be used only as temporary connections during initial configuration or troubleshooting.

The serial console port implements RS232 DCE (Data Communication Equipment) on a DB9 connector. The following is the pin-out for the port:

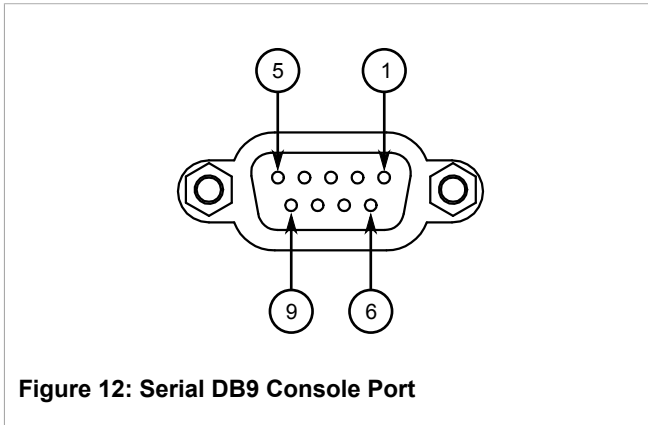

Figure 12: Serial DB9 Console Port

Pin	Name	Description
1	DCD	Data Carrier Detect
2	RX	Receive Data
3	TX	Transmit Data
4	DTR	Data Terminal Ready
5	GND	Signal Ground
6	DSR	Data Set Ready
7	RTS	Request to Send
8	CTS	Clear To Send
9	Reserved (Do Not Connect)	

The management port is a 10/100Base-TX copper Ethernet port with an RJ45 connector. The following is the pin-out for the management port:

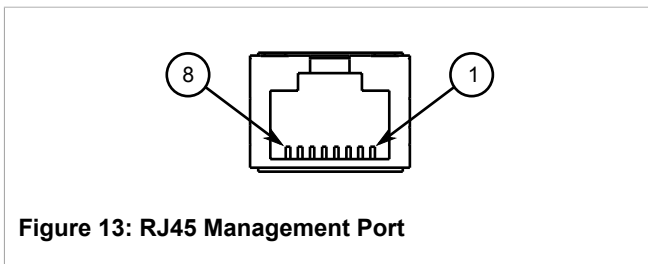

Figure 13: RJ45 Management Port

Pin	Name	Description
1	RX+	Receive Data+
2	RX-	Receive Data-
3	TX+	Transmit Data+
4	Reserved (Do Not Connect)	
5	Reserved (Do Not Connect)	
6	TX-	Transmit Data-
7	Reserved (Do Not Connect)	
8	Reserved (Do Not Connect)	

Communication Ports

Connect to any of the available Ethernet ports on the device to access the ROX II console and Web interfaces via the device's IP address. For more information about available ports, refer to [Chapter 3, Communication Ports](#).

Section 2.6

Cabling Recommendations

Siemens recommends using SIMATIC NET industrial Ethernet shielded cables for all Ethernet ports.

Refer to the following sections for further recommendations and considerations:

- [Section 2.6.1, "Protection On Twisted-Pair Data Ports"](#)
- [Section 2.6.2, "Gigabit Ethernet 1000Base-TX Cabling Recommendations"](#)

Section 2.6.1

Protection On Twisted-Pair Data Ports

Siemens does not recommend the use of copper cabling of any length for critical, real-time substation automation applications. All copper Ethernet ports on RUGGEDCOM products include transient suppression circuitry to protect against damage from electrical transients and conform with IEC 61850-3 and IEEE 1613 Class 1 standards. This means that during a transient electrical event, communications errors or interruptions may occur, but recovery is automatic.

Siemens also does not recommend using copper Ethernet ports to interface with devices in the field across distances that could produce high levels of ground potential rise (i.e. greater than 2500 V), during line-to-ground fault conditions.

Section 2.6.2

Gigabit Ethernet 1000Base-TX Cabling Recommendations

The IEEE 802.3ab Gigabit Ethernet standard defines 1000 Mbit/s Ethernet communications over distances of up to 100 m (328 ft) using all 4 pairs in category 5 (or higher) balanced, unshielded twisted-pair cabling. For wiring guidelines, system designers and integrators should refer to the Telecommunications Industry Association (TIA) TIA/EIA-568-A wiring standard that characterizes minimum cabling performance specifications required for proper Gigabit Ethernet operation. For reliable, error-free data communication, new and pre-existing communication paths should be verified for TIA/EIA-568-A compliance.

The following table summarizes the relevant cabling standards:

Cabling Category	1000Base-TX Compliant	Required Action
< 5	No	New wiring infrastructure required.
5	Yes	Verify TIA/EIA-568-A compliance.
5e	Yes	No action required. New installations should be designed with Category 5e or higher.
6	Yes	No action required.
> 6	Yes	Connector and wiring standards to be determined.

Follow these recommendations for copper data cabling in high electrical noise environments:

- Data cable lengths should be as short as possible, preferably 3 m (10 ft) in length. Copper data cables should not be used for inter-building communications.
- Power and data cables should not be run in parallel for long distances, and should be installed in separate conduits. Power and data cables should intersect at 90° angles when necessary to reduce inductive coupling.

3 Communication Ports

The RX1501 can be equipped with various types of communication ports to enhance its abilities and performance. Each set of communication ports is part of a field replaceable module that makes switching ports fast and easy.

Use the ROX II software to determine which ports are equipped on the device. For more information, refer to the *ROX II User Guide* for the RX1501.

Modules can be installed in most of the available slots in the RX1501 chassis.

**NOTE**

Copper, 100Base-FX and Gigabit Ethernet (GbE) modules with only 2 ports can only be installed in slots 1 and 2.

**NOTE**

Only one T1/E1 module is allowed.

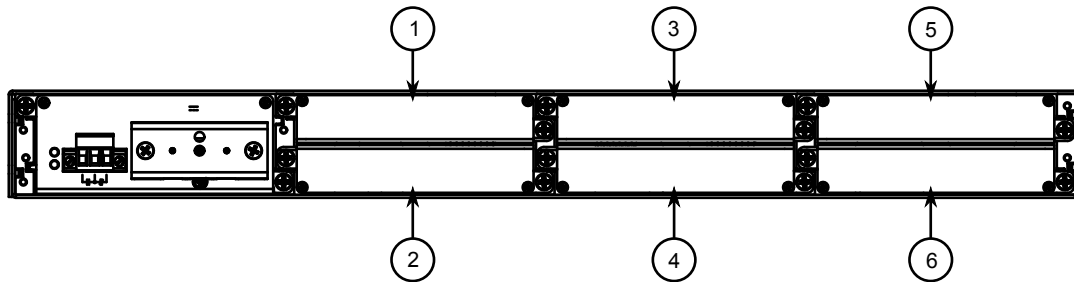

Figure 14: Available Chassis Slots

1. Slot 1 2. Slot 2 3. Slot 5 4. Slot 6

The following sections describe the available ports in more detail:

- [Section 3.1, “Copper Ethernet Ports”](#)
- [Section 3.2, “Fiber Optic Ethernet Ports”](#)
- [Section 3.3, “SFP Optic Ethernet Ports”](#)
- [Section 3.4, “WAN Modules”](#)
- [Section 3.5, “Serial Ports”](#)
- [Section 3.6, “Cellular Modem Modules”](#)
- [Section 3.7, “DDS \(Digital Data Services\) Modules”](#)
- [Section 3.8, “RUGGEDCOM APE Module”](#)
- [Section 3.9, “Installing/Removing Modules”](#)
- [Section 3.10, “Connecting Multiple RS485 Devices”](#)

Section 3.1

Copper Ethernet Ports

The RX1501 supports several 10/100Base-TX Ethernet ports with RJ45 or M12 (bypass or non-bypass) connectors. The RJ45 and M12 connectors are directly connected to the chassis ground on the device and can accept CAT-5 shielded twisted-pair (STP) cables.



CAUTION!

Contamination hazard – risk of damage to equipment. M12 modules are shipped with internal O-rings and dust caps to prevent the ingress of dirt and debris that may damage the port. Make sure the O-rings and dust caps are installed on all unused M12 ports.

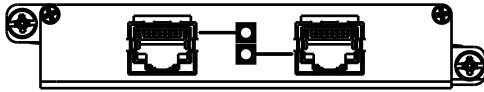

Figure 15: 2 x 10/100/1000TX with RJ45 Ports

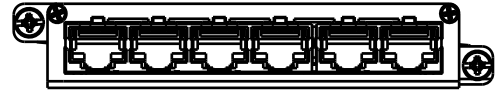

Figure 16: 6 x 10/100TX with RJ45 Ports



Figure 17: 2 x 8-Pin 10/100/1000TX with M12 A-Coded Ports



Figure 18: 2 x 8-Pin 10/100/1000TX with M12 A-Coded Bypass Ports



Figure 19: 2 x 8-Pin 10/100/1000TX with M12 X-Coded Ports



Figure 20: 2 x 8-Pin 10/100/1000TX with M12 X-Coded Bypass Ports



Figure 21: 4 x 8-Pin 10/100TX with M12 A-Coded Ports



Figure 22: 4 x 8-Pin 10/100TX with M12 A-Coded Bypass and Non-Bypass Ports

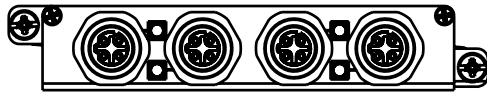

Figure 23: 4 x 4-Pin 10/100TX M12 D-Coded Ports



Figure 24: 4 x 4-Pin 10/100TX with M12 D-Coded Bypass and Non-Bypass Ports

Each port features an LED that indicates the state of the port.

State	Description
Green (Solid)	Link established
Green (Blinking)	Activity
Off	No link detected

The following are the pin-out descriptions for the RJ45 and M12 connectors:

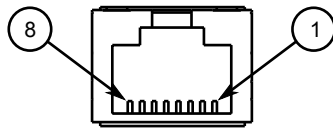

Figure 25: RJ45 Ethernet Port Pin Configuration

Pin	Name		Description
	10/100Base-TX	1000Base-TX	
1	RX+	BI_DB+	Receive Data+ or Bi-Directional
2	RX-	BI_DB-	Receive Data- or Bi-Directional
3	TX+	BI_DA+	Transmit Data+ or Bi-Directional
4	Reserved (Do Not Connect)		
5	Reserved (Do Not Connect)		
6	TX-	BI_DA-	Transmit Data- or Bi-Directional
7	Reserved (Do Not Connect)		
8	Reserved (Do Not Connect)		

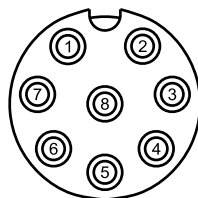

Figure 26: 8-Pin M12 A-Coded Ethernet Port Pin Configuration

Pin	10/100Base-Tx Signal	10/100/1000Base-Tx Signal
1	Reserved (Do Not Connect) ^a	C+
2	Reserved (Do Not Connect) ^a	D+
3	Reserved (Do Not Connect) ^a	D-
4	TX-	A-
5	RX+	B+
6	TX+	A+
7	Reserved (Do Not Connect) ^a	C-



Figure 27: 8-Pin M12 X-Coded Ethernet Port Pin Configuration

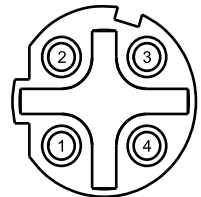

Figure 28: 4-Pin M12 D-Coded Ethernet Port Pin Configuration

Pin	10/100Base-Tx Signal	10/100/1000Base-Tx Signal
8	RX-	B-

Pin	10/100/1000Base-Tx Signal
1	A+
2	A-
3	B+
4	B-
5	D+
6	D-
7	C+
8	C-

Pin	10/100Base-Tx Signal
1	TX+
2	RX+
3	TX-
4	RX-

^a Terminated at GND (Ground)

For specifications on the available copper Ethernet ports, refer to [Section 4.4, “Copper Ethernet Port Specifications”](#).

Section 3.2

Fiber Optic Ethernet Ports

Fiber optic Ethernet ports are available with either MTRJ (Mechanical Transfer Registered Jack), LC (Lucent Connector), SC (Standard or Subscriber Connector) or ST (Straight Tip) connectors. Make sure the Transmit (Tx) and Receive (Rx) connections of each port are properly connected and matched to establish a proper link.

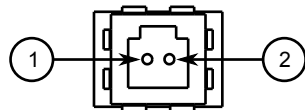

Figure 29: MTRJ Port

1. Tx Connector 2. Rx Connector

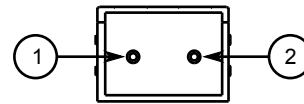

Figure 30: LC Port

1. Tx Connector 2. Rx Connector

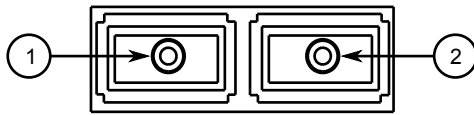

Figure 31: SC Port

1. Tx Connector 2. Rx Connector

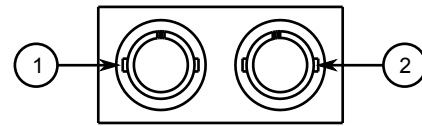

Figure 32: ST Port

1. Tx Connector 2. Rx Connector

For specifications on the available fiber optic Ethernet ports, refer to [Section 4.5, “Fiber Optic Ethernet Port Specifications”](#).

Section 3.3

SFP Optic Ethernet Ports

SFP (Small Form-Factor Pluggable) optic Ethernet ports are available with LC (Lucent Connector) connectors. Make sure the Transmit (Tx) and Receive (Rx) connections of each port are properly connected and matched to establish a proper link.

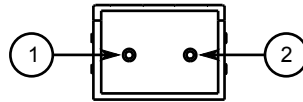

Figure 33: LC Port

1. Tx Connector 2. Rx Connector



NOTE

SFP modules, as well as their optical ports, can be safely inserted and removed while the chassis is powered and operating.

The following sections describe how to install and remove SFP optical ports:

- [Section 3.3.1, “Installing an SFP Optical Port”](#)
- [Section 3.3.2, “Removing an SFP Optical Port”](#)

Section 3.3.1

Installing an SFP Optical Port

To install an SFP optical port, do the following:



CAUTION!

Electrical hazard – risk of damage to equipment. Use only components certified by Siemens with RUGGEDCOM products. Damage to the module and device may occur if compatibility and reliability have not been properly assessed.



CAUTION!

Electrical hazard – risk of damage to equipment. Make sure all electrostatic energy is dissipated before installing or removing components from the device. An electrostatic discharge (ESD) can cause serious damage to the component once it is outside the chassis.

1. Make sure all potential electrostatic build-up has been properly discharged to prevent electrostatic discharges (ESD). This can be accomplished by wearing an ESD wrist strap or by touching Earth or the chassis ground.
2. Remove the dust cover from the port opening in the module.



CAUTION!

Mechanical hazard – risk of component damage. SFP optical ports are designed to insert in only one orientation. Do not force the port into the module.

3. Remove the port from its packaging.
4. Insert the port into the module and swing the bail-latch up to lock it in place.

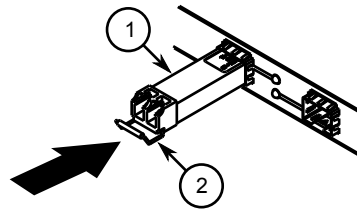

Figure 34: Installing an SFP Optical Port (Typical)

1. SFP Optical Port 2. Metal Bail-Latch

5. Remove the dust cover from the port.
6. Connect a cable to the port and test the connection.

Section 3.3.2

Removing an SFP Optical Port

To remove an SFP optical port, do the following:



CAUTION!

Electrical hazard – risk of damage to equipment. Make sure all electrostatic energy is dissipated before performing installing or removing components from the device. An electrostatic discharge (ESD) can cause serious damage to the component once it is outside the chassis.

1. Make sure all potential electrostatic build-up has been properly discharged to prevent electrostatic discharges (ESD). This can be accomplished by wearing an ESD wrist strap or by touching Earth or the chassis ground.
2. Disconnect the cable from the port.
3. Swing the metal bail-latch down and pull the port from the module.

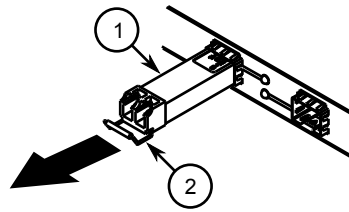

Figure 35: Removing an SFP Optical Port (Typical)

1. SFP Optical Port 2. Metal Bail-Latch

4. Store the port in an ESD-safe bag or other suitable ESD-safe environment, free from moisture and stored at the proper temperature (-40 to 85 °C or -40 to 185 °F).
5. Insert a plug in the empty port opening to prevent the ingress of dust and dirt.

Section 3.4

WAN Modules

The RX1501 supports the following WAN (Wide Area Network) line modules:



NOTE

- Only one T1/E1 WAN module may be used per router.
- The TC1 and TC2 WAN modules comply with Part 68 of the FCC rules and requirements adopted by ACTA. The product identifier is provided on a label on top of the modules. If requested, this information must be provided to the telephone company.
- The TC1 and TC2 WAN modules meet the Industry Canada's CS-03 Part II, Issue 9 technical specifications. The industry Canada registration number and model number is provided on a label on top of the modules.
- The WAN modules TC1 and TC2 use only RJ48C connectors.
- The modules have no user serviceable parts and equipment must only be repaired by authorized Siemens personnel only.



Figure 36: 1 × T1/E1 with RJ45 Ports (TC1)

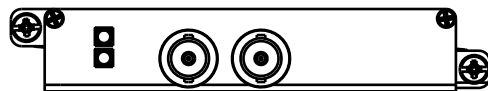

Figure 37: 1 × E1 with BNC Ports (E01)

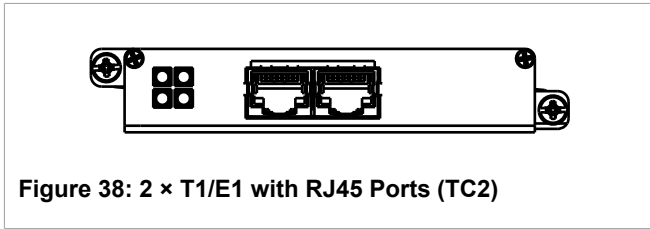

Figure 38: 2 x T1/E1 with RJ45 Ports (TC2)

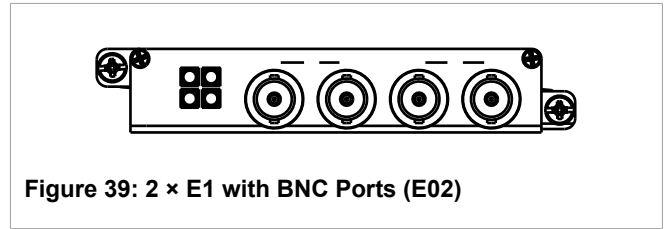

Figure 39: 2 x E1 with BNC Ports (E02)

The following is the pin-out for the BNC and RJ45 connectors:

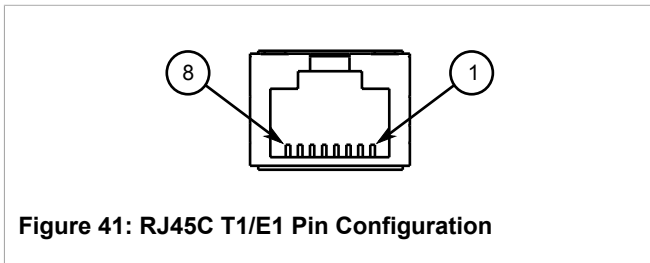
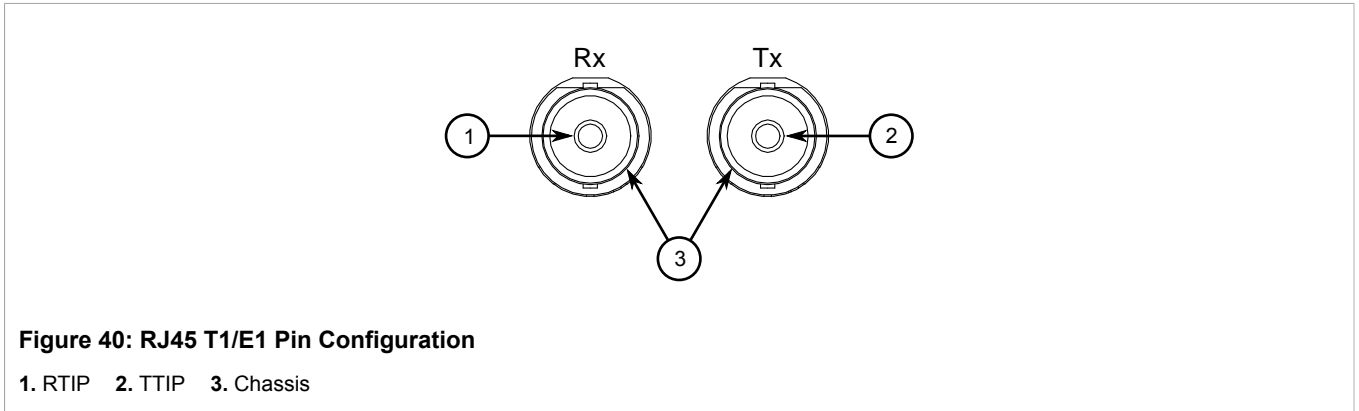

Figure 41: RJ45C T1/E1 Pin Configuration

Pin	Name	Description
1	RRING	Receive Negative
2	RTIP	Receive Positive
3		Reserved (Do Not Connect)
4	TRING	Transmit Negative
5	TTIP	Transmit Positive
6		Reserved (Do Not Connect)
7		Reserved (Do Not Connect)
8		Reserved (Do Not Connect)

Section 3.5

Serial Ports

The RX1501 supports RJ45 serial ports, which can be run in RS232, RS485 or RS422 mode.



NOTE

On power-up, all serial ports default to RS485 mode. Each port can be individually set to RS232, RS485 or RS422 mode through ROX II. For more information, refer to the ROX II User Guide for the RX1501.

All serial ports feature an LED that indicates the current state of the port.

State	Description
Green	Activity detected
Off	No activity

For specifications on serial ports, refer to [Section 4.3, “Copper Serial Port Specifications”](#).

For information about how to connect devices configured to run in RS485 mode, refer to [Section 3.10, “Connecting Multiple RS485 Devices”](#).

The following are the pin-outs for the RJ45 connectors:

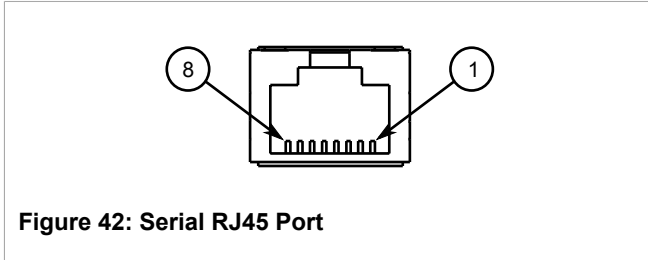

Figure 42: Serial RJ45 Port

Pin	RS232 Mode	RS485 Mode	RS422 Mode
1			RX- (Receive Negative)
2	Reserved (Do Not Connect)		
3	Common (Isolated) Ground		
4			
5	RX (Receive)		RX+ (Receive Negative)
6	TX (Transmit)	TX/RX+ (Transmit/Receive Positive)	TX+ (Transmit Positive)
7	Note ^b		
8	Note ^b	TX/RX- (Transmit/Receive Negative)	TX- (Transmit Negative)
Shield	Chassis Ground		

^b Pins 7 and 8 are connected together internally.

Section 3.6

Cellular Modem Modules

The RX1501 supports the following cellular modem line modules for operation on GSM, EDGE, HSPA+, or CDMA networks:



DANGER!

Radio interference hazard – risk of death, serious personal injury or equipment damage. Do not operate the cellular modem in the following areas:

- Areas where explosives are actively used
- In explosive atmospheres, such as refueling stations, fuel depots, chemical plants, underground mining operations, etc.
- Near medical or life support equipment or devices
- In any aircraft, whether in flight or on the ground (unless permitted by the aircraft operator)

In such areas, the cellular modem must be turned off. Otherwise the cellular modem can transmit signals that may interfere with nearby equipment that is susceptible to radio interference.



WARNING!

Communication disruption hazard – risk of serious personal injury, equipment damage, or data loss. Wireless communications are susceptible to disruptions that may result in the delay, corruption or loss of data. While cellular disruptions are uncommon when using a Siemens cellular modem, avoid using the cellular modem in applications where a communication failure could result in damage to equipment or personal injury to persons in the area. Siemens accepts no responsibility for any damages that may result due to wireless disruptions.



NOTE

The cellular modems feature 50 Ω SMA antenna connectors on the front plate of each module. The HSPA option is available for use on various GSM-based networks. This option supports GSM, GPRS, EDGE, UMTS and WCDMA/HSDPA/HSUPA. The Main antenna and Receive Diversity antenna connections are made to the 50 Ω SMA connectors.



NOTE

If two or more antennas are to be installed, the antennas must be separated by a minimum distance of 20 cm (7.9 in).



IMPORTANT!

If the device is intended for use in a portable device, separate approval is required to satisfy the SAR requirements of FCC Part 2.1093 and IC RSS-102.

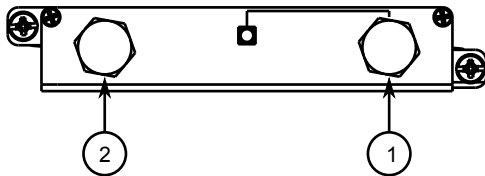

Figure 43: W11 and W21 Cellular Modems

1. Main Antenna SMA Connector 2. Receive Diversity Antenna SMA Connector

Order Code	Description
W11	1 Port Cell Modem GSM,EDGE,HSPA+
W21	1 Port Cell Modem EVDO Rev.A Verizon Wireless

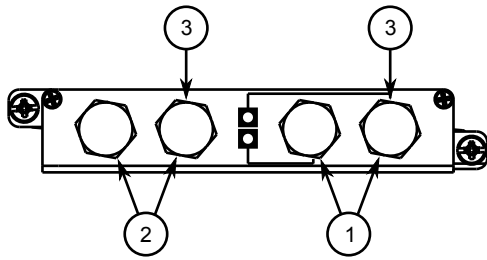

Figure 44: W12, W22 and W32 Cellular Modems

1. Main Antenna SMA Connector 2. Receive Diversity Antenna SMA Connector 3. Antenna for First/Primary Cell Modem

Order Code	Description
W12	2 Port Cell Modem GSM,EDGE,HSPA+
W22	2 Port Cell Modem EVDO Rev.A Verizon Wireless
W32	1 Port Cell Modem GSM,EDGE,HSPA+, 1 Port Cell Modem EVDO Rev.A Verizon Wireless

The following sections describe the cellular modem modules in more detail:

- [Section 3.6.1, “Cellular Modem Installation Requirements”](#)
- [Section 3.6.2, “Diversity Requirements”](#)
- [Section 3.6.3, “Supported Frequency Bands”](#)
- [Section 3.6.4, “Installing SIM Cards for GSM, EDGE and HSPA+ Cellular Modems”](#)

Section 3.6.1

Cellular Modem Installation Requirements

The cellular modem module is approved for modular use in mobile applications. The module, as part of the RX1501, can be integrated into a final product without additional certification from the Federal Communications Commission (FCC) or Industry Canada (IC) if the application meets the following requirements:



NOTE

If this module is integrated into a portable device, separate approval related to the Specific Absorption Rate (SAR) requirements of FCC Part 2.1093 and IC RSS-102 is required.

- Persons in the area must be kept at least 20 cm (8 in) from the antenna at all times.
- The antenna gain, including cable loss, must not exceed the maximum rating specified in [Section 3.6.3, “Supported Frequency Bands”](#).
- The cellular modem and antenna must not be next to or operate in conjunction with another transmitter or antenna within a host device.
- A label must be affixed to the end product that indicates the FCC and IC IDs for the cellular modem.

Cellular Modem	FCC ID	IC ID
W11, W12	N7MC8705	2417C-MC8705
W21, W22	N7MC5728	2417C-MC5728
W32	N7MC8705 and N7MC5728	2417C-MC8705 and 2417C-MC5728

- The user documentation for the end product must clearly indicate the operating requirements and conditions that comply with current FCC and IC radio frequency exposure guidelines.
- The end product must comply with the unintentional emission testing requirements of FCC Part 15.

If the application does not meet these requirements, further certification is required.

Section 3.6.2

Diversity Requirements

Diversity, where two antennas exist within the same physical housing, is a method for improving radio signal strength. When two antennas are present, the following requirements must be met:

- Antenna isolation must be minimum 10 dB to prevent the receive antenna from picking up too much power from the transmit antenna.
- Performance characteristics of the transmit and receive antennas must be comparable.
- The performance of the receive antenna, as measured by forward link throughput, must be 0 to 3 dB better than a single antenna.

Section 3.6.3

Supported Frequency Bands

The following frequency bands are supported by the available cellular modem modules.



WARNING!

Electromagnetic radiation hazard – risk of serious injury. Do not exceed the maximum antenna gain. Aside from causing cellular interference for other devices that use the same band, adverse health effects for individuals in the area may occur.

Band	Frequency Range				RX Diversity Support	Maximum Allowable Gain (dBi) ^c
	Tx (MHz)	VSWR	Rx (MHz)	VSWR		
Band I WCDMA 2100	1920-1980	< 2.5:1	2110-2170	< 3.5:1	✓	4
Band II WCDMA 1900	1850-1910	< 2.5:1	1930-1990	< 2.5:1	✓	4
Band VIII WCDMA 900	880-915	< 2.5:1	925-960	< 3.5:1	✓	5
Band V WCDMA 850	824-849	< 2.5:1	869-894	< 3.5:1	✓	5
Band VI WCDMA 800	830-840	< 2.5:1	875-885	< 3.5:1	✓	5
GSM 850	824-849	< 2.5:1	869-894	< 3.5:1	✗	5
EGSM 900	880-915	< 2.5:1	925-960	< 3.5:1	✗	5
GSM 1800	1710-1785	< 2.5:1	1805-1880	< 3.5:1	✗	4
GSM 1900	1850-1910	< 2.5:1	1930-1990	< 2.5:1	✗	4

^c Gain limits are reported on certification grants, for consideration against Radio Frequency (RF) exposure and Effective Radiated Power (ERP)/Effective Isotropic Radiated Power (EIRP) limits.

Section 3.6.4

Installing SIM Cards for GSM, EDGE and HSPA+ Cellular Modems

To install a SIM card in a GSM, EDGE or HSPA+ cellular modem, do the following:



CAUTION!

Static electricity hazard – risk of damage to equipment. Make sure to take appropriate anti-static precautions before opening the cellular modem module.

1. Remove the module from the chassis.
2. On the smooth side of the module, remove the four screws and separate the back of the module from the module chassis.

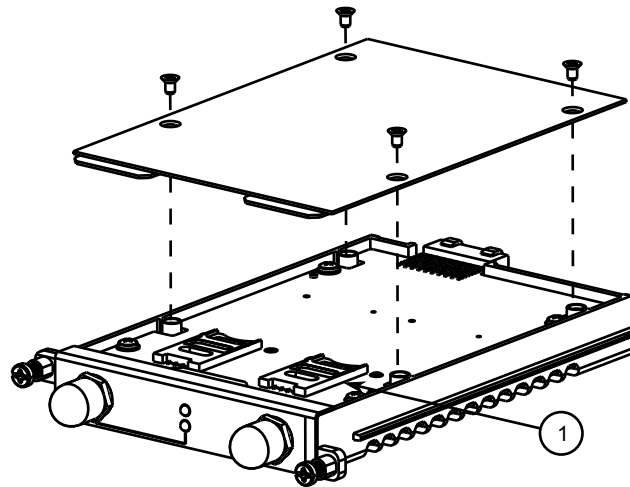

Figure 45: W11, W21 Cellular Modem

1. SIM Card Cage 1

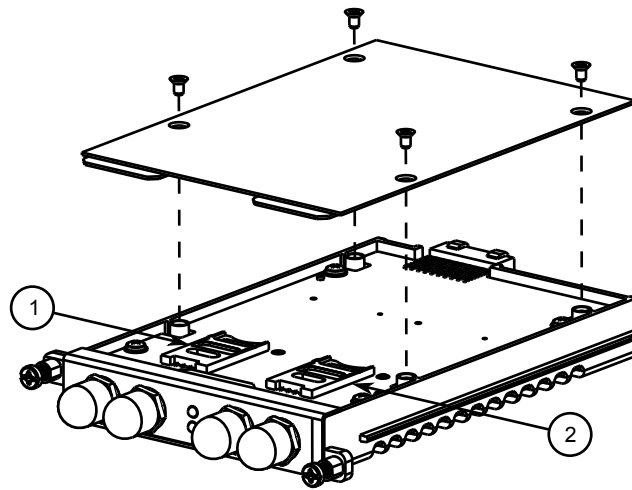

Figure 46: W12, W22, W32 Cellular Modem

1. SIM Card Cage 2 2. SIM Card Cage 1

3. Open SIM card cage 1 by sliding the silver catch towards the antenna connectors and flip the cage up.
4. Insert a SIM card in to the cage.
5. Close SIM card cage 1 by flipping the cage down and slide the silver catch away from the antenna connectors.
6. For W12, W22 and W32 cellular modems, repeat [Step 3](#) to [Step 5](#) install a SIM card in SIM card cage 2.
7. Install the back of the module and secure it to the module chassis with the four screws removed previously.
8. Install the module. For more information, refer to [Section 3.9.1, "Installing a Module"](#).

Section 3.7

DDS (Digital Data Services) Modules

The RX1501 can be equipped with a DDS port line module that supports 56 kbps (Master/Slave) and 64 kbps (Slave) line rates.

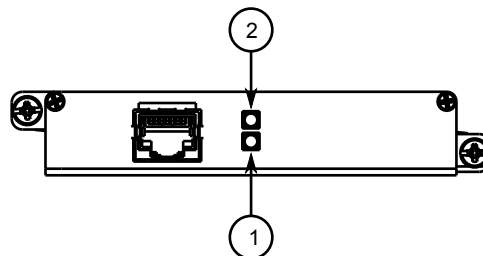

Figure 47: 1 × DDS with RJ45 Ports (D02)

1. Rx LED 2. Tx LED

The module is compatible with the following standards:

- AT&T PUB 62310 (Standard DDS)
- BELLCORE TA-TSY-000077
- BELLCORE TR-TSY-000458
- ANSI T1.410

It also supports the following operating modes:

Operating Mode	Line Rate
DDS-PRI	56 kbps
CC-64K	72 kbps

Each RJ45 port features a **RX** and **TX** LED that indicates the state of the port.

LED	LED Color	Status
Rx	Green	Frame sync detected and signal OK.
Tx		The interface is enabled and remote device has no errors.
Rx	Yellow	Signal OK, but no frame sync.
Tx		The interface is in loopback mode.
Rx	Red	Loss of signal.
Tx		Loss of signal or receiving any of OOS, UNM, or UMC codes: the remote device is out of service or has problems with the signal.
Rx	Off	The interface is not enabled.
Tx		The interface is not enabled.

The following is the pin-out for the DDS RJ45 ports:

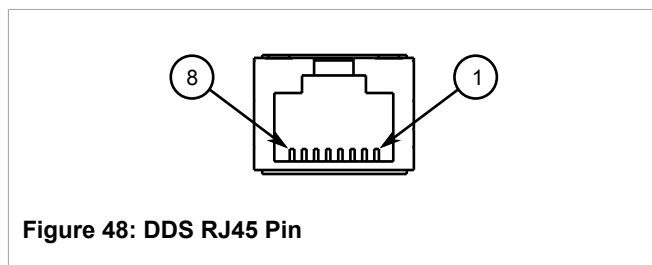

Figure 48: DDS RJ45 Pin

Pin	Description
1	Transmit data to network (Tip)
2	Transmit data to network (Ring)
3	Reserved (Do Not Connect)
4	Reserved (Do Not Connect)
5	Reserved (Do Not Connect)
6	Reserved (Do Not Connect)
7	Receive data from network (Tip)
8	Receive data from network (Ring)

Section 3.8

RUGGEDCOM APE Module

The RX1501 supports various versions of the RUGGEDCOM APE (Application Processing Engine) module. The APE is an x86-based computer design that can host a variety of x86-based operating systems. It also features

Gigabit Ethernet (GbE) ports, USB ports and a DVI-D video port. For more information about RX1501 APE, including installation and setup instructions, refer to the *RUGGEDCOM APE User Guide*.



CAUTION!

Electrical hazard – risk of power failure. Installing more APE modules than allowed can lead to power fluctuations and irregular shut downs. Do not install more than two APE modules on the device.



Figure 49: RUGGEDCOM APE Module

For specifications, refer to [Section 4.8, “RUGGEDCOM APE Specifications”](#).

Section 3.9

Installing/Removing Modules

The following sections describe how to install and remove modules:

- [Section 3.9.1, “Installing a Module”](#)
- [Section 3.9.2, “Removing a Module”](#)

Section 3.9.1

Installing a Module

Upon installing a new module in the device, all the features associated to the module are available in the operating system. For more information, refer to the *ROX II User Guide* for the RX1501.

To install a module, do the following:

1. Make sure power to the device has been disconnected and wait approximately two minutes for any remaining energy to dissipate.
2. If the device is installed in a rack, remove it from the rack.
3. Remove the current module from the slot. For more information, refer to [Section 3.9.2, “Removing a Module”](#).
4. Insert the new module into the slot.

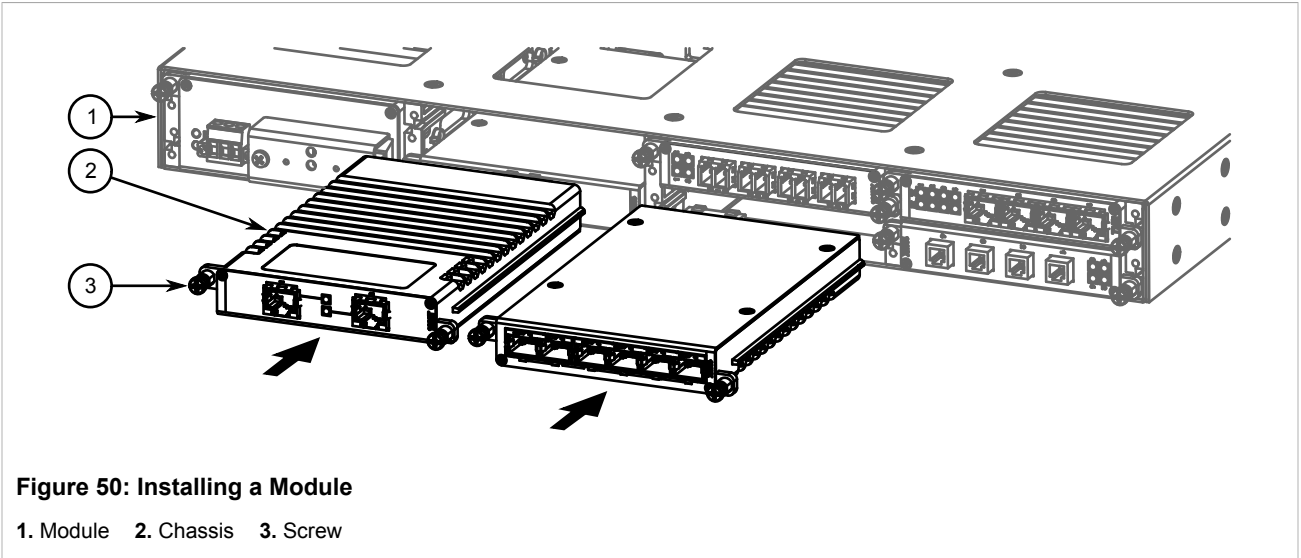

5. Tighten the screws to secure the module.
6. If necessary, install the device in the rack.
7. Connect power to the device.

Section 3.9.2

Removing a Module

Once a module is removed, all the features associated with the module are hidden or disabled in the operating system.

To remove a module, do the following:

1. Make sure power to the device has been disconnected and wait approximately two minutes for any remaining energy to dissipate.
2. If the device is installed in a rack, remove it from the rack.
3. Loosen the screws that secure the module.
4. Pull the module from the chassis to disconnect it.

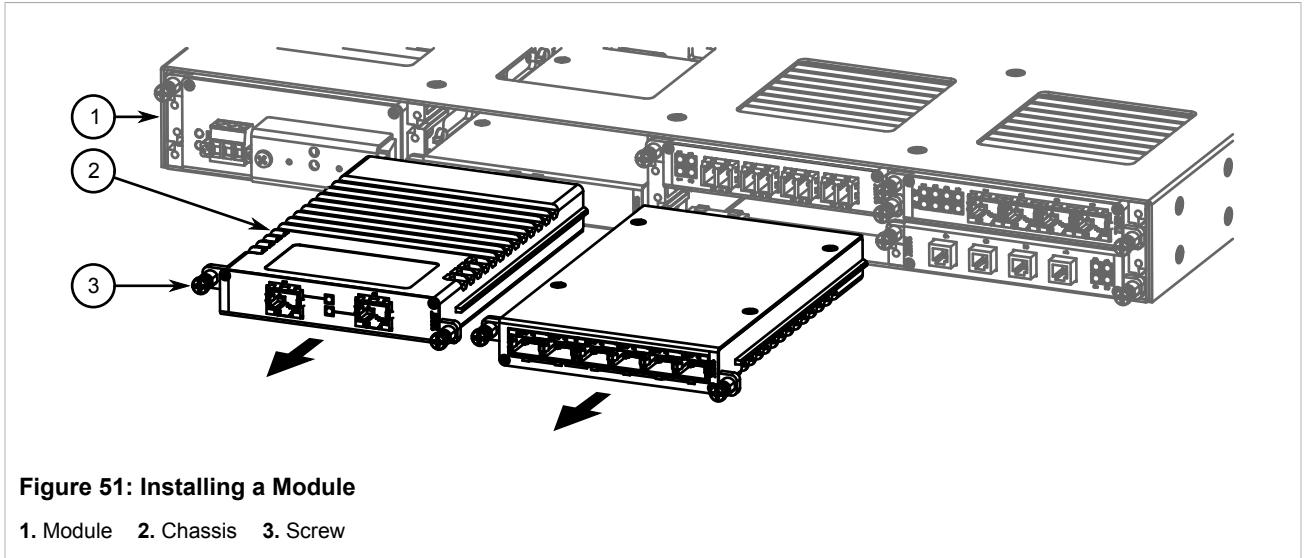

5. Install a new module or a blank module (to prevent the ingress of dust and dirt). For more information, refer to [Section 3.9.2, “Removing a Module”](#).
6. If necessary, install the device in the rack.
7. Connect power to the device.

Section 3.10

Connecting Multiple RS485 Devices

Each RS485 port can communicate with multiple RS485 devices by wiring devices together in sequence over a single twisted pair with transmit and receive signals on the same two wires (half duplex). For reliable, continuous communication, adhere to the following guidelines:

- To minimize the effects of ambient electrical noise, use shielded cabling.
- The correct polarity must be observed throughout a single sequence or ring.
- The number of devices wired should not exceed 32, and total distance should be less than 1219 m (4000 ft) at 100 kbps.
- The Common terminals should be connected to the common wire inside the shield.
- The shield should be connected to earth ground at a single point to avoid loop currents.
- The twisted pair should be terminated at each end of the chain.

The following shows the recommended RS485 wiring.

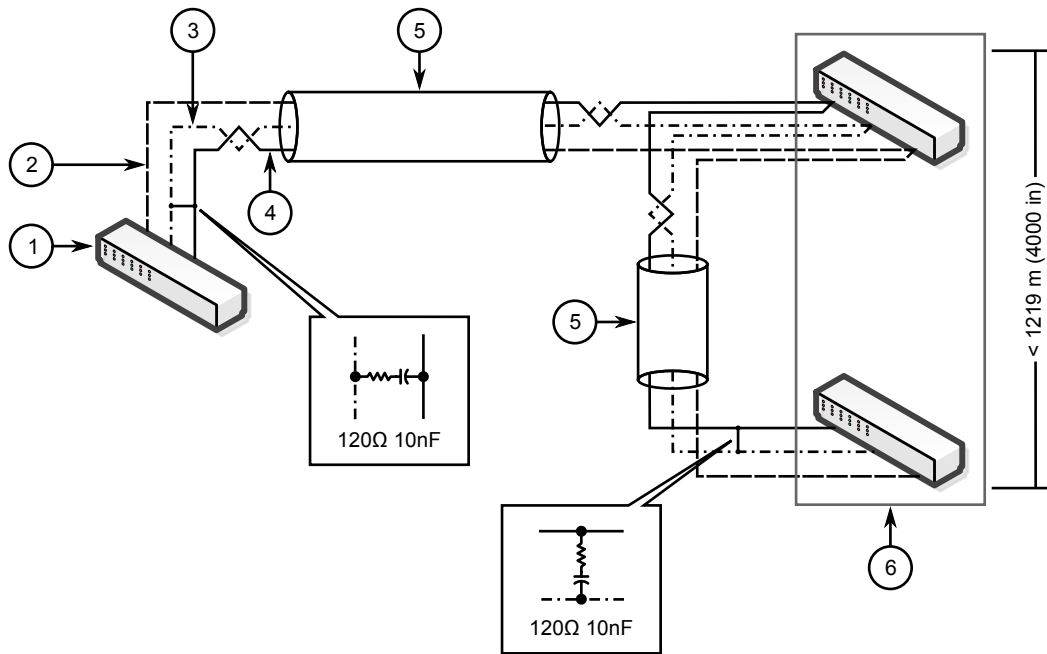

Figure 52: Recommended RS485 Wiring

1. RX1501 Device 2. Common (Isolated Ground) 3. Negative 4. Positive 5. Shield to Earth (Connected At a Single Point)
6. RS485 Devices (32 Total)

4 Technical Specifications

The following sections provide important technical specifications related to the device and available modules:

- [Section 4.1, “Power Supply Specifications”](#)
- [Section 4.2, “Failsafe Relay Specifications”](#)
- [Section 4.3, “Copper Serial Port Specifications”](#)
- [Section 4.4, “Copper Ethernet Port Specifications”](#)
- [Section 4.5, “Fiber Optic Ethernet Port Specifications”](#)
- [Section 4.6, “Cellular Modem Specifications”](#)
- [Section 4.7, “Operating Environment”](#)
- [Section 4.8, “RUGGEDCOM APE Specifications”](#)
- [Section 4.9, “Mechanical Specifications”](#)

Section 4.1

Power Supply Specifications

Power Supply Type	Input Range		Internal Fuse Rating	Maximum Power Consumption ^a	Maximum Cable Length ^b	Insulation
	Min	Max				
HI	88 VDC	300 VDC	3.15 A(T) ^c	65 W	—	2800 VDC for 1 minute
	85 VAC	264 VAC				
HIP	88 VDC	300 VDC	3.15 A(T) ^c	65 W	—	
	85 VAC	264 VAC				
24	13 VDC	36 VDC	10 A(T) ^c	63.5 W	9.4 m (30.8 ft)	1500 VDC for 1 minute
24P						
48	36 VDC	72 VDC	3.15 A(T) ^c	60 W	45.5 m (149 ft)	
48P						
12	9 VDC	15 VDC	12 A	67 W	5.5 m (18 ft)	1500 VAC or 2121 VDC for 1 minute
12P						

^a Power consumption varies based on the device configuration.

^b Based on #16 AWG wiring.

^c (T) denotes time-delay fuse.

Section 4.2

Failsafe Relay Specifications

Maximum Switching Voltage	Rated Switching Current	Isolation
30 VDC	5 A	2800 VDC for 1 minute
250 VAC	6.25 A	

Section 4.3

Copper Serial Port Specifications

Baud Rate	Connector	Isolation
1200 to 230400 kbps	RJ45	2500 VDC for 1 minute

Section 4.4

Copper Ethernet Port Specifications

The following details the specifications for copper Ethernet ports that can be ordered with the RX1501.

Speed ^d	Connector	Mode	Duplex ^d	Cable Type ^e	Wiring Standard ^f	Maximum Distance	Isolation ^g
10/100/1000TX	RJ45	—	FDX/ HDX	> CAT-5	TIA/EIA T568A/B	100 m (328 ft)	1.5 kV
10/100/1000TX	8-Pin A-Coded M12	—	FDX/ HDX	> CAT-5	TIA/EIA T568A/B	100 m (328 ft)	1.5 kV
10/100/1000TX	8-Pin A-Coded M12	Controlled Bypass	FDX/ HDX	> CAT-5	TIA/EIA T568A/B	100 m (328 ft)	1.5 kV
10/100/1000TX	8-Pin X-Coded M12	—	FDX/ HDX	> CAT-5	TIA/EIA T568A/B	100 m (328 ft)	1.5 kV
10/100/1000TX	8-Pin X-Coded M12	Controlled Bypass	FDX/ HDX	> CAT-5	TIA/EIA T568A/B	100 m (328 ft)	1.5 kV
10/100TX	RJ45	—	FDX/ HDX	> CAT-5	TIA/EIA T568A/B	100 m (328 ft)	1.5 kV
10/100TX	8-Pin A-Coded M12	—	FDX/ HDX	> CAT-5	TIA/EIA T568A/B	100 m (328 ft)	1.5 kV
10/100TX	8-Pin A-Coded M12	Controlled Bypass	FDX/ HDX	> CAT-5	TIA/EIA T568A/B	100 m (328 ft)	1.5 kV
10/100TX	4-Pin A-Coded M12	—	FDX/ HDX	> CAT-5	TIA/EIA T568A/B	100 m (328 ft)	1.5 kV
10/100TX	4-Pin A-Coded M12	Controlled Bypass	FDX/ HDX	> CAT-5	TIA/EIA T568A/B	100 m (328 ft)	1.5 kV

^d Auto-negotiating.

^e Shielded or unshielded.

^f Auto-crossover and auto-polarity.

^g RMS 1 minute.

Section 4.5

Fiber Optic Ethernet Port Specifications

The following sections detail fiber optic specifications for ports that can be equipped on the RX1501. The user determines the type of optics at the time of ordering, and can determine the ports installed on a particular unit by reading the factory data file via the ROX II user interface. The specifications are organized by order code. Module order codes are contained within each unit when it is assembled and configured at the factory. For information about obtaining factory configuration data, refer to the *ROX II User Guide* for the RX1501.

- [Section 4.5.1, “Fast Ethernet \(100 Mbps\) Optical Specifications”](#)
- [Section 4.5.2, “Gigabit Ethernet \(1 Gbps\) Optical Specifications”](#)

Section 4.5.1

Fast Ethernet (100 Mbps) Optical Specifications

Fixed Fast Ethernet Transceivers

Mode	Connector Type	Cable Type (µm)	Tx λ (typ.) (nm)	Tx min. (dBm)	Tx max. (dBm)	Rx Sensitivity (dBm)	Rx Saturation (dBm)	Distance (typ.) (km)	Power Budget (dB)
MM	ST	62.5/125	1300	-19	-14	-31	-14	2	12
		50/125		-22.5					8.5
MM	SC	62.5/125	1300	-19	-14	-31	-14	2	12
		50/125		-22.5					8.5
MM	MTRJ	62.5/125	1300	-19	-14	-31	-14	2	12
		50/125		-22.5					8.5
MM	MTRJ	62.5/125	1300	-19	-14	-31	-14	2	12
		50/125		-22.5					8.5
SM	ST	9/125	1300	-15	-8	-32	-3	20	17
SM	SC	9/125	1300	-15	-8	-31	-7	20	16
SM	LC	9/125	1300	-15	-8	-34	-7	20	19
SM	LC	9/125	1300	-15	-8	-34	-7	20	19
SM	SC	9/125	1300	-5	0	-34	-3	50	29
SM	LC	9/125	1300	-5	0	-35	3	50	30
SM	LC	9/125	1300	-5	0	-35	3	50	30
SM	SC	9/125	1300	0	5	-37	0	90	37
SM	LC	9/125	1300	0	5	-37	0	90	37
SM	LC	9/125	1300	0	5	-37	0	90	37

Mode	Connector Type	Cable Type (µm)	Tx λ (typ.) (nm)	Tx min. (dBm)	Tx max. (dBm)	Rx Sensitivity (dBm)	Rx Saturation (dBm)	Distance (typ.) (km)	Power Budget (dB)
MM	MTRJ	62.5/125	1300	-19	-14	-31	-14	2	12
	LC	50/125		-22.5					8.5
LC	50/125	-22.5	8.5						

SFP Fast Ethernet Transceivers

Mode	Connector Type	Cable Type (µm)	Tx λ (typ.) (nm)	Tx min (dBm)	Tx max (dBm)	Rx Sensitivity (dBm)	Rx Saturation (dBm)	Distance (typ.) (km)	Power Budget (dB)
MM	LC	62.5/125	1310	-20	-14	-31	-14	2	11
		50/125		-23.5					7.5
MM	LC	62.5/125	1310	-20	-14	-31	-14	2	11
		50/125		-23.5					7.5
SM	LC	9/125	1300	-15	-8	-31	-8	15	16
SM	LC	9/125	1300	-15	-8	-31	-8	15	16
SM	LC	9/125	1300	-5	0	-34	0	40	29
SM	LC	9/125	1300	-5	0	-34	0	40	29
SM	LC	9/125	1550	-5	0	-34	-10	80	29
SM	LC	9/125	1550	-5	0	-34	-10	80	29

Section 4.5.2

Gigabit Ethernet (1 Gbps) Optical Specifications



NOTE

- Maximum segment length is greatly dependent on factors such as fiber quality, and the number of patches and splices. Consult a Siemens sales associate when determining maximum segment distances.
- All optical power numbers are listed as dBm averages.
- F51 transceivers are rated for -40 to 85 °C (-40 to 185 °F).

Fixed Gigabit Transceivers

Mode	Connector Type	Cable Type (µm)	Tx λ (typ.) (nm)	Tx min (dBm)	Tx max (dBm)	Rx Sensitivity (dBm)	Rx Saturation (dBm)	Distance (typ.) (km)	Power Budget (dB)
MM	LC	50/125	850	-9	-2.5	-20	0	0.5	11
SM	SC	9/125	1310	-10	-3	-20	-3	10	10
SM	LC	9/125	1310	-9.5	-3	-21	-3	10	11.5
SM	SC	9/125	1310	-5	0	-20	-3	25	15

Mode	Connector Type	Cable Type (μm)	Tx λ (typ.) (nm)	Tx min (dBm)	Tx max (dBm)	Rx Sensitivity (dBm)	Rx Saturation (dBm)	Distance (typ.) (km)	Power Budget (dB)
SM	LC	9/125	1310	-7	-3	-24	-3	25	17

SFP Gigabit Transceivers

Mode	Connector Type	Cable Type (μm)	Tx λ (typ.) (nm)	Tx min (dBm)	Tx max (dBm)	Rx Sensitivity (dBm)	Rx Saturation (dBm)	Distance (typ.) (km)	Power Budget (dB)
MM	LC	50/125	850	-9	-2.5	-20	0	0.5	11
		62.5/125						0.3	
SM	LC	9/125	1310	-9.5	-3	-19	-3	10	9.5
SM	LC	9/125	1310	-7	-3	-23	-3	25	16
SM	LC	9/125	1550	0	5	-23	-3	70	23

Section 4.6

Cellular Modem Specifications

Conducted Tx (Transmit) Power Tolerances for W11, W12 and W32 (Primary Radio) Cellular Modems

System/Operating Band	Frequency Band (MHz)	Conducted Tx Power (dBm)	Comment
GSM-850 and GSM-900 ^h	850/900	+32 ± 1	GMSK mode, connectorized (class 4)
		+27 ± 1	8PSK mode, connectorized (class E2)
DCS-1800 and PCS-1900 ^h	1800/1900	+29 ± 1	GMSK mode, connectorized (class 1)
		+26 ± 1	8PSK mode, connectorized (class E2)
Band I	2100	+23 ± 1	AMR 12.2 kbps, connectorized (class 3)
Band II, V, VI and VIII	800, 850, 900 and 1900		

^h Circuit-Shared

Typical Radio Frequency (RF) for W21, W22 and W32 (Secondary Radio) Cellular Modems

System/Operating Band	Frequency Band (MHz)		Conducted Tx Power (dBm)
	Transmit (Tx)	Receive (Rx)	
PCS	1851 to 1910	1930 to 1990	23 to 25
Cellular	824 to 849	869 to 894	

Operating Temperature

Module	Operating Temperature	Compliance
W11, W12, W32 (First Radio)	-25 to 60 °C (-13 to 140 °F)	Full Radio Frequency (RF) compliance

Module	Operating Temperature	Compliance
W21, W22, W32 (Second Radio)	60 to 75 °C (140 to 167 °F)	Reduced Radio Frequency (RF) performance
	-30 to 60 °C (-22 to 140 °F)	Full Radio Frequency (RF) compliance
	60 to 75 °C (140 to 167 °F)	Reduced Radio Frequency (RF) performance

Section 4.7

Operating Environment



NOTE

The ambient operating temperature is reduced for devices equipped with a cellular modem. For more information, refer to [Section 4.6, “Cellular Modem Specifications”](#).

Parameter	Range	Comments
Ambient Operating Temperature	-40 to 85 °C (-40 to 185 °F) ⁱ	Measured from a 30 cm (12 in) radius surrounding the center of the enclosure.
Ambient Relative Humidity	5% to 95%	Non-condensing
Ambient Storage Temperature	-40 to 85 °C (-40 to 185 °F)	

ⁱ Maximum ambient operating temperature is 70 °C (158 °F) when the device is installed along with Underwriter Laboratories (UL) listed devices.

Section 4.8

RUGGEDCOM APE Specifications

Feature	APE1402	APE1402W7	APE1404	APE1404W7	APE1404CKP
Processor	Intel Atom E660 1.3 GHz, 512 KB L2 Cache		Intel Atom E660T 1.3 GHz, 512 KB L2 Cache		
RAM	2 GB DDR2, 800 MHz, 32-bit				
Disk	8 GB SATA, solid state		16 GB SATA, solid state		
Networking	Realtek RTL8111, RJ45 Gigabit Ethernet interface				
USB	2 x USB 2.0, maximum combined USB device power consumption 500 mA at 5 V				
Video	Intel 4108 Graphics Processor, DVI-D				
LED Indications	Power and Disk				
Controls	Momentary contact reset button				
Temperature Range	-40 to 70 °C (-40 to 158 °F)				
Power Requirements	12 W with no USB load, 14.5 W with full USB load				
Software Platform	Debian Linux®	Windows® Embedded Standard 7	Debian Linux®	Windows® Embedded Standard 7	Check Point GAIa™ OS

Section 4.9

Mechanical Specifications

Parameter	Value
Dimensions	Refer to Chapter 5, Dimension Drawings
Weight	Approximately 4.7 kg (10.3 lb)
Ingress Protection	IP40
Enclosure	Aluminum

5 Dimension Drawings



NOTE

All dimensions are in millimeters, unless otherwise stated.

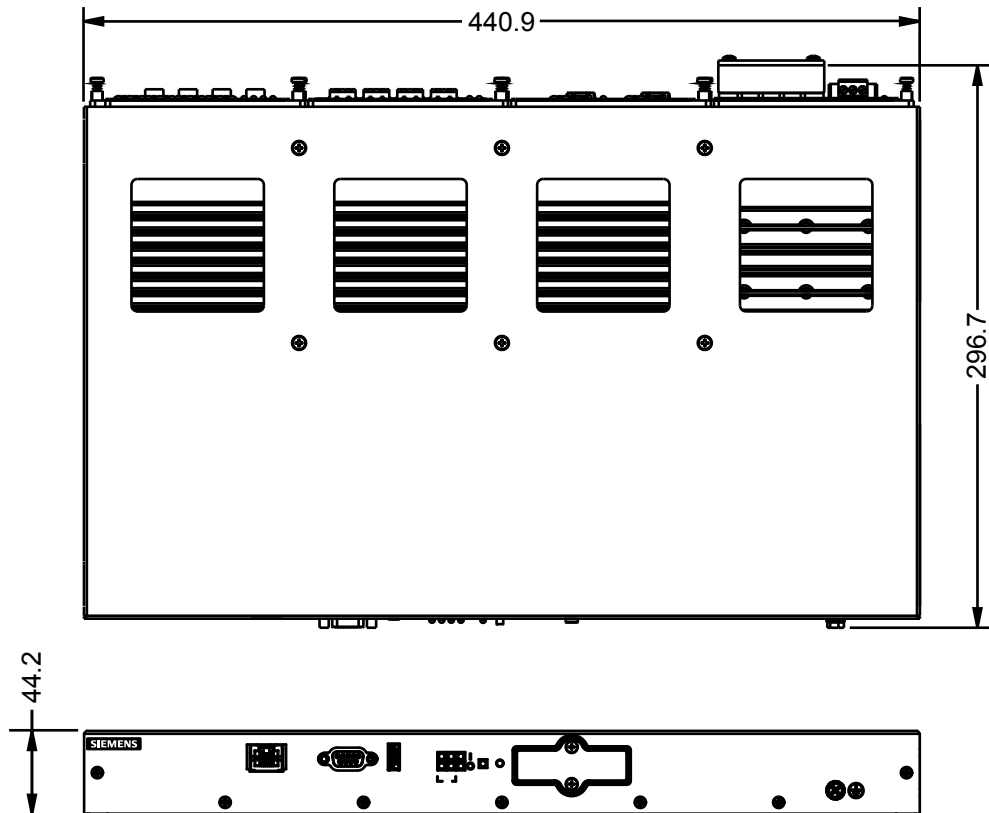

Figure 53: Overall Dimensions

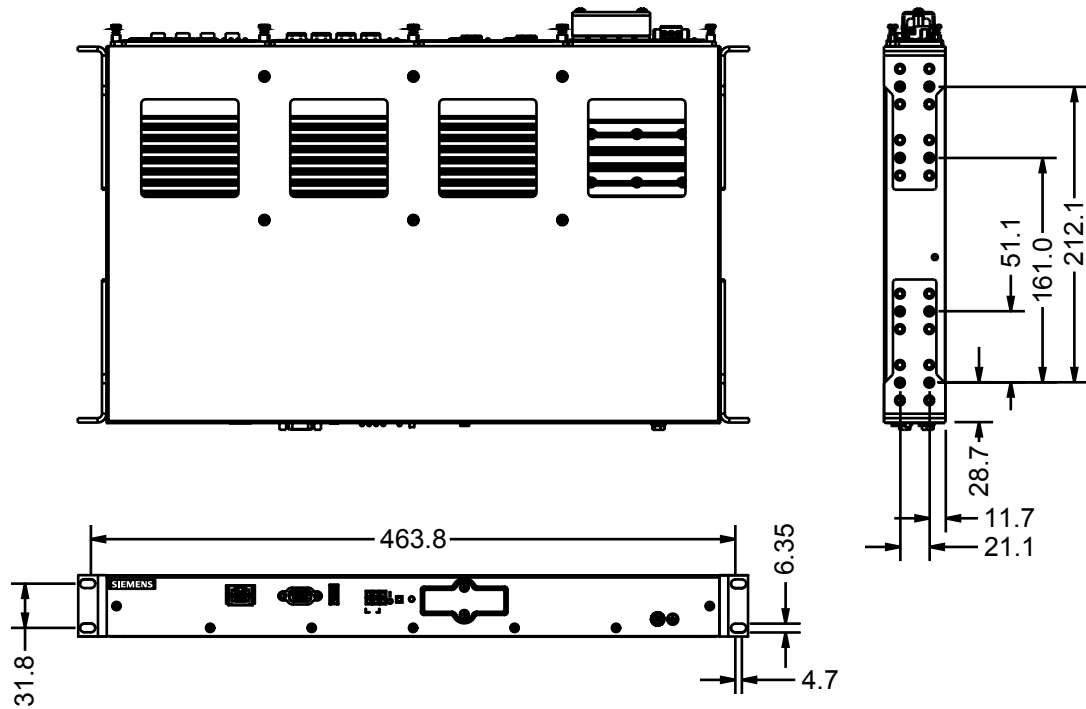

Figure 54: Rack Mount Dimensions

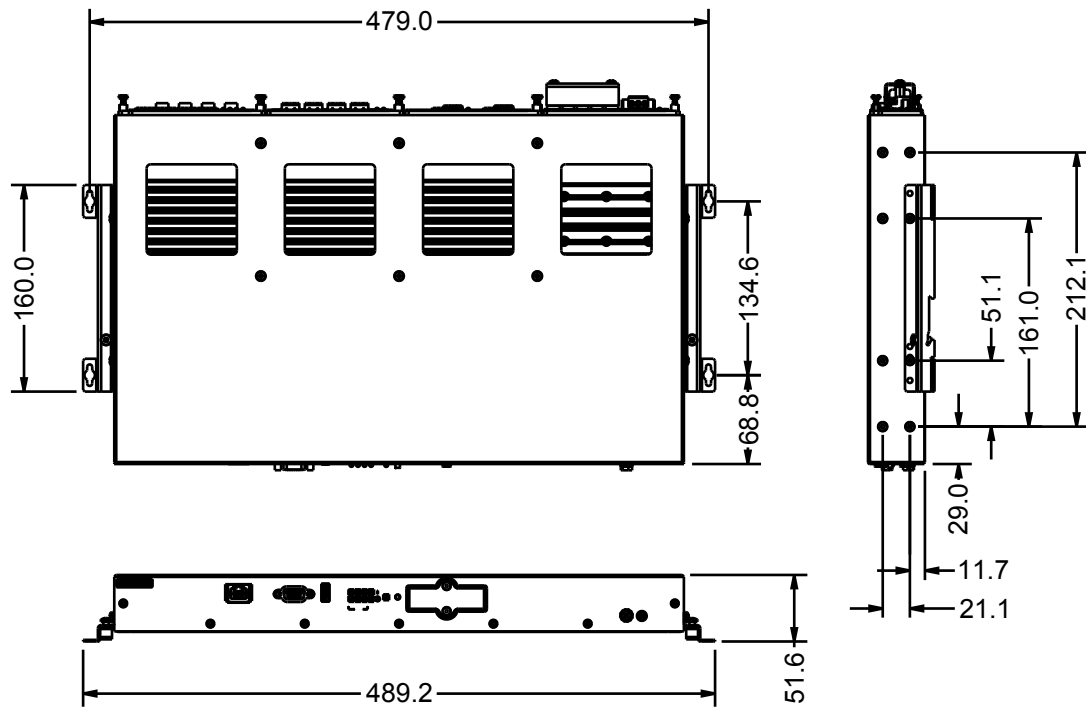

Figure 55: Panel and Din Rail Mount Dimensions

6 Certification

The RX1501 device has been thoroughly tested to guarantee its conformance with recognized standards and has received approval from recognized regulatory agencies.

- [Section 6.1, “Agency Approvals”](#)
- [Section 6.2, “FCC Compliance”](#)
- [Section 6.3, “Industry Canada Compliance”](#)
- [Section 6.4, “EMI and Environmental Type Tests”](#)

Section 6.1

Agency Approvals

Agency	Standards	Comments
TUV	UL 60950-1:2007 CAN/CSA-C22.2 No. 60950-1-07	Approved File E361664
CE	EN 60950-1, EN 61000-6-2, EN 55022, EN 60825-1, EN 50581	CE Compliance is claimed via Declaration of Self Conformity Route
FCC	FCC Part 15, Class A	Approved
	FCC Part 15, Subpart B	Cellular LM Models RX1500PN-W11-XX RX1500PN-W12-XX RX1500PN-W32-XX FCC ID for W11 and W12: N7NMC8705 FCC ID for W32: N7NMC8705/N7N-MC5728
FDA/CDRH	21 CFR Chapter I, Sub-chapter J	Laser Eye Safety
ISO	ISO9001:2008	Designed and manufactured using an ISO9001: 2008 certified quality program
ACTA	FCC Part 68	TC1, TC2 and TC4 line modules
Industry Canada	IC CS-03 Part II, Issue 9	TC1, TC2 and TC4 line modules
		Cellular LM Models RX1500PN-W11-XX RX1500PN-W12-XX RX1500PN-W32-XX IC ID for W11 and W12: 2417C-MC8705 IC ID for W32: 2417C-MC8705/2417C-MC5728
		Cellco Partnership d/b/a Verizon Wireless Open Development Certification Agreement MA-004198-2012 Carrier Certification for Cellular LM Models RX1500PN-W21-XX RX1500PN-W22-XX RX1500PN-W32-XX
		AT&T

Agency	Standards	Comments
		Cellular LM Models RX1500PN-W11-XX RX1500PN-W12-XX RX1500PN-W32-XX FCC ID for W11 and W12: N7NMC8705 FCC ID for W32: N7NMC8705/N7N-MC5728 IC ID for W11 and W12: 2417C-MC8705 IC ID for W32: 2417C-MC8705/2417C-MC5728

Section 6.2

FCC Compliance

This equipment has been tested and found to comply with the limits for a Class A digital device pursuant to Part 15 of the FCC Rules. These limits are designed to provide reasonable protection against harmful interference when the equipment is operated in a commercial environment.

This equipment generates, uses and can radiate radio frequency energy and, if not installed and used in accordance with the instruction manual, may cause harmful interference to radio communications. Operation of this equipment in a residential area is likely to cause harmful interference in which case the user will be required to correct the interference on his own expense.

Section 6.3

Industry Canada Compliance

CAN ICES-3 (A) / NMB-3 (A)

Section 6.4

EMI and Environmental Type Tests

The RX1501 has passed the following EMI and environmental tests.

IEC 61850-3 EMI Type Tests

Test	Description		Test Levels	Severity Levels
IEC 61000-4-2	ESD	Enclosure Contact	+/- 8 kV	4
		Enclosure Air	+/- 15 kV	
IEC 61000-4-3	Radiated RFI	Enclosure Ports	20 V/m	Note ^a
IEC 61000-4-4	Burst (Fast Transient)	Signal ports	+/- 4 kV @ 2.5 kHz	
		DC Power Ports	+/- 4 kV	
		AC Power Ports		
Earth ground ports				

Test	Description		Test Levels	Severity Levels
IEC 61000-4-5	Surge	Signal ports	+/- 4 kV Line-to-Earth, +/- 2 kV Line-to-Line	4
		DC Power Ports	+/- 2 kV Line-to-Earth, +/- 1 kV Line-to-Line	3
		AC Power Ports	+/- 4 kV Line-to-Earth, +/- 2 kV Line-to-Line	4
IEC 61000-4-6	Induced (Conducted) RFI	Signal ports	10 V	3
		DC Power Ports		
		AC Power Ports		
		Earth ground ports		
IEC 61000-4-8	Magnetic Field	Enclosure Ports	40 A/m, continuous, 1000 A/m for 1 s	Note ^a
			1000 A/m for 1 s	5
IEC 61000-4-29	Voltage Dips and Interrupts	DC Power Ports	30% for 0.1 s, 60% for 0.1 s, 100% for 0.05 s	
		AC Power Ports		
IEC 61000-4-11	Voltage Dips and Interrupts	AC Power Ports	100% for 5 periods, 100% for 50 periods	
IEC 61000-4-12	Damped Oscillatory	Signal ports	2.5 kV common, 1 kV differential mode @1 MHz	3
		DC Power Ports		
		AC Power Ports		
IEC 61000-4-16	Mains Frequency Voltage	Signal ports	30 V Continuous, 300 V for 1 s	4
		DC Power Ports		
IEC 61000-4-17	Ripple on DC Power Supply	DC Power Ports	10%	3
IEC 60255-5	Dielectric Strength	Signal ports	2 kVAC (Failsafe Relay output)	
		DC Power Ports	1.5 kVDC	
		AC Power Ports	2 kVAC	
	HV Impulse	Signal ports	5 kV (Failsafe Relay output)	
		DC Power Ports	5 kV	
		AC Power Ports		

^a Siemens-specified severity levels

IEEE 1613 (C37.90.x) EMI Immunity Type Tests



NOTE

The RX1501 meets Class 2 requirements for an all-fiber configuration and Class 1 requirements for copper ports.

Test	Description		Test Levels
IEEE C37.90	HV Impulse	Signal ports	5 kV (Failsafe Relay Output)
		DC Power Ports	5 kV
		AC Power Ports	
	Dielectric Strength	Signal ports	2 kVAC
		DC Power Ports	1.5 kVDC
		AC Power Ports	2 kVAC
IEEE C37.90.1	Fast Transient	Signal ports	+/- 4 kV @ 2.5 kHz
		DC Power Ports	+/- 4 kV
		AC Power Ports	
		Earth ground ports	
	Oscillatory	Signal ports	2.5 kV common mode @1MHz
		DC Power Ports	2.5 kV common, 1 kV differential mode @ 1 MHz
		AC Power Ports	
IEEE C37.90.2	Radiated RFI	Enclosure ports	35 V/m
IEEE C37.90.3	ESD	Enclosure Contact	+/-2 kV, +/-4 kV, +/- 8 kV
		Enclosure Air	+/-4 kV, +/-8 kV, +/-15 kV

Environmental Type Tests

Test	Description		Test Levels
IEC 60068-2-1	Cold Temperature	Test Ad	-40 °C (-40 °F), 16 Hours
IEC 60068-2-2	Dry Heat	Test Bd	85 °C (185 °F), 16 Hours
IEC 60068-2-30	Humidity (Damp Heat, Cyclic)	Test Db	95% (non-condensing), 55 °C (131 °F), 6 cycles
IEC 60255-21-1	Vibration		Level 2 (2 g @ 10-150 Hz)
IEC 60255-21-2	Shock		Level 2 (30 g @ 11 mS)
	Bump		Level 1 (10 g @ 16 mS)
IEC 60255-21-3	Seismic		Level 2 (Method A)
MIL-STD-810G	Altitude		12192 m (40000 ft) @ 40 °C x 90 minutes
IEC 61373	Long Life		Category 1 Class B
	Shock		